



POWER SPOT 700 II

User Manual

Table of Contents

1. Introduction 5
 Unpacking 5
 Customer Support 5
 Discharge Lamp Precautions 6

2. Safety Instructions..... 8

3. Features.....9

4. General Guidelines.....10

5. Fixture Layout 12

6. Mounting and Installation 16

7. Understanding DMX..... 19
 7.1 DMX-512 19
 7.2 DMX Linking 19
 7.3 DMX Cables 19
 7.4 DMX Termination 20
 7.5 DMX Addressing 21

8. Fixture Menu..... 23
 8.1 Setting the DMX - Address (D001)..... 24
 8.2 Test Program (TEST) 25
 8.3 Audio Program 25
 8.3 Lamp On/Off (LAMP)..... 26
 8.5 Reset (RESE)..... 26
 8.6 Running Time (lamp/unit) (TIME) 26
 8.7 Invert Pan Movement (RPAN)..... 26
 8.8 Invert Tilt Movement (RTLTL) 27
 8.9 Special Functions (SPEC)..... 27
 8.9.1 *Manual Drive* (MANU)..... 27
 8.9.2 *Lamp On (automatic)* (LAAU) 27
 8.9.3 *Lamp Off (via DMX)* 28
 8.9.4 *DMX Input* (DLOF)..... 28
 8.9.5 *LED Display* (DISP) 29
 8.9.6 *Fixture Temperature* (TEMP)..... 29
 8.9.7 *Fan Control* (FANS)..... 30

8.9.8	<i>Adjustments and Calibrations (ADJU)</i>	31
8.9.9	<i>Default Settings (DFSE)</i>	32
8.9.10	<i>Feedback (FEED)</i>	32
8.9.11	<i>Fault Corrections (EFLD)</i>	32
8.10	Error and Information Messages	32
9.	Operating Modes	34
9.1	Universal DMX Control	34
9.2	Stand Alone (Sound Active)	34
9.3	Master-Slave	35
10.	DMX Channel Traits (DMX Protocol)	37
11.	Lamp Replacement	47
11.1	Safety Regulations	47
11.2	Lamp Optimization	48
12.	Fuse Replacement	50
13.	Optical Effects Module	51
13.1	Safety Considerations	51
13.2	Removing the Effects Module	51
14.	Changing/Replacing Gobos/Colors	55
14.1	General Guidelines	55
14.2	Changing Gobos	57
14.3	Changing Color Filters	57
14.4	Gobo Patterns	58
15.	Maintenance and Cleaning	59
16.	Warranty	61
17.	Photometric Data	63
18.	Dimensions	64
19.	Technical Specification	65
20.	Index	67

Power Spot 700 II™

INTRODUCTION: Congratulations, you have just purchased one of the most innovative and reliable lighting fixtures on the market today! The Power Spot 700 II™, has been designed to perform reliably for years when the guidelines in this booklet are followed. Please read and understand the instructions in this manual carefully and thoroughly before attempting to operate this unit. These instructions contain important information regarding safety during use and maintenance.

UNPACKING: Thank you for purchasing the Power Spot 700 II™ by Elation Professional®. Every Power Spot 700 II™ has been thoroughly tested and has been shipped in perfect operating condition. Carefully check the shipping carton for damage that may have occurred during shipping. If the carton appears to be damaged, carefully inspect your unit for damage and be sure all accessories necessary to operate the unit have arrived intact. In the event damage has been found or parts are missing, please contact our customer support team for further instructions. Please do not return this unit to your dealer without first contacting customer support at the number listed below.

CUSTOMER SUPPORT: Elation Professional® provides a customer support line, to provide set up help and to answer any question should you encounter problems during your set up or initial operation. You may also visit us on the web at www.elationlighting.com for any comments or suggestions. For service related issue please contact Elation Professional®. Service Hours are Monday through Friday 8:00 a.m. to 5:00 p.m. Pacific Standard Time.

Voice: (866) 245-6726

Fax: (323) 832-9142

E-mail: support@elationlighting.com

Forum: www.ElationLighting.com/forum/

Warning! To prevent or reduce the risk of electrical shock or fire, do not expose this unit to rain or moisture.

Caution! There are no user serviceable parts inside this unit. Do not attempt any repairs yourself, doing so will void your manufactures warranty.

Please do not discard the shipping carton in the trash. Please recycle whenever possible.

WARRANTY REGISTRATION: The Power Spot 700 II™ carries a two year (730 days)

Power Spot 700 II™

limited warranty. Please fill out the enclosed warranty card to validate your purchase. All returned service items whether under warranty or not, must be freight pre-paid and accompany a return authorization (R.A.) number. The R.A. number must be clearly written on the outside of the return package. A brief description of the problem as well as the R.A. number must also be written down on a piece of paper and included in the shipping container. If the unit is under warranty, you must provide a copy of your proof of purchase invoice. Items returned without a R.A. number clearly marked on the outside of the package will be refused and returned at customer's expense. You may obtain a R.A. number by contacting customer support at (323) 582-3322.

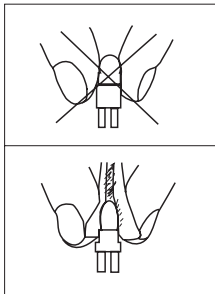

DISCHARGE LAMP WARNING: This fixture is fitted with a discharge lamp, which is highly susceptible to damage if improperly handled. Never touch the lamp with your bare hands, as the oil from your hands will shorten lamp life. Also, never move the fixture until the lamps have had ample time to cool. Remember, lamps are not covered under warranty conditions.

This fixture emits intense UV radiation, which is harmful to the eyes and skin. The intense luminance of the lamp can cause severe damage to the retina. Never operate this fixture with the protective covers removed, these covers have been specially designed to shield against UV radiation.

Epileptic Warning: *Those suffering from epilepsy should avoid looking directly into the lamp at all times.*

Avoid switching the fixture on and off repeatedly in short intervals, as this will reduce lamp life and intensity.

To achieve the intensity associated with discharge lamps, these lamps use a gas sealed in a high-pressure environment to emit a brilliant output. Due to the high pressure involved with the construction of the lamp, the lamp may explode during prolonged extensive use. This risk is increased with age; added care is encouraged when dealing with older lamps. Thus, lamp should always be replaced at the end of their recommended duty cycle. Extreme caution should be used when operated this or any fixture fitted with a gas discharge lamp.

Power Spot 700 II™

Never open this fixture while in use!

During the initial operation of this fixture, a light smoke or smell may emit from the interior of the fixture. This is a normal process and is caused by excess paint in the interior of the casing burning off from the heat associated with the lamp.

This device falls under protection-class 1. Therefore it is essential that the device be grounded properly.

All electrical connections must be performed by qualified personnel.

Be sure the available voltage matches the voltage requirements of the unit.

Be sure the power cord is never crimped or damaged. If the power cord is damaged, replace it immediately with a new one of similar power rating.

Always disconnect from main power before performing any type of service or any cleaning procedure.

Only handle the power cord by the plug. Never pull out the plug by tugging the wire portion of the cord.

Please be aware that damages caused by modifications to the device are not subject to warranty.

2. SAFETY INSTRUCTIONS



The Power Spot 700 II™ is an extremely sophisticated piece of electronic equipment. To guarantee a smooth operation, it is important to follow the guidelines in this manual. The manufacturer of this device will not accept responsibility for damages resulting from the misuse of this fixture due to the disregard of the information printed in this manual.

1. Always be sure that the fan and the air inlets remain clean and are never blocked. Allow about 6" (15cm) between this fixture and other devices or a wall to allow for proper cooling.
2. Never touch the fixture during normal operation. This can cause severe personal injuries and/or damage to the fixture.
3. Be sure to unplug the POWER SPOT 700 II™ from the power outlet before performing any service related issues.
4. Lamp Replacement; Allow at least 30 minutes after disconnecting main power before you open the POWER SPOT 700 II™. To prevent personal injury, never touch the lamp if you are not absolutely sure it has cooled.
5. Never look directly into the lamp beam. You risk injury to your retina, which may induce blindness.
6. Be sure to track and record the lamp running time. The lamp should be changed at the end of the specified lamp life, regardless of lamp output. You may also have to change the lamp if it shows any deformations or damage. The same is with all glass components, color filters, lenses and mirrors.
7. For safe operation, follow the Installation guide described in chapter two of this manual. Operating the POWER SPOT 700 II™ without suited safety aids such as safety cables or clamps can increase the risk of damage and/or personal injury.
8. Installation should only be performed by qualified and certified personal.
9. When mounting this fixture, use only the original rigging parts included with this fixture. Any structural modification will void the original manufactures warranty and may increase the risk of damage and/or personal injury.
10. To reduce the risk of fire or shock, do not expose this unit to rain or moisture.
11. Do not attempt to operate this fixture if the power cord is frayed or damaged.

3. FEATURES

- Pan 530° / Tilt 280°
- 3 operation mode: DMX controlled, stand alone or sound activated
- Electronic Power Supply
- Control board with 4-digit display
- Digital display can be turned 180° to fit different installation position
- 2 Color Wheels:
 - Color Wheel: 16 User exchangeable colors
- 3 Gobo Wheels:
 - Fixed: 9 plus open
 - Rotating: 14 User replaceable plus open
- Auto test for all functions
- Automatic Pan/Tilt Correction
- Glass Dichroic Reflector for Even Lamp Output
- Anti-Reflective Coated Lenses
- Brilliant MSR700/2 Lamp (700w, 1000Hrs, 7200K)
- USITT DMX-512 Complaint
- Value of each DMX-channel can be displayed
- Uses 24 DMX Channels (16-bit mode)
- Variable Frost Filter
- 3-Facet Prism
- User Replaceable Color and Gobos
- Intergraded Tilt Lock System
- Modular Construction
- Variable Zoom: 14°~32° (Beam Angle)
- Motor Driven Focus
- Variable Iris (4%~100%)

4. GENERAL GUIDELINES

This fixture is a professional lighting effect designed for use on stage, in nightclubs, in theatres, etc. Do not attempt operation or installation without a proper knowledge on how to so.

This fixture was designed for indoor use only.

Consistent operational breaks may ensure that the fixture will function properly for many years to come.

Do not shake the fixture around. Avoid brute force when installing or operating the device.

While choosing an installation location, please be sure that the fixture will not be exposed to extreme heat, moisture or dust. The minimum distance between the fixture and a wall or flat surface should be at least .5 meter (about 1.5ft).

Always install the fixture with an appropriate safety cable. When installing the fixture in a suspended environment always be to use mounting hardware no less than M10 x 25 mm, also be sure the hardware is insert in the pre-arranged screw holes in the base of the fixture.

When using the quick release “Omega” cam-lock system, be sure the four quick lock fasteners are locked in the quick lock holes correctly, see page 16 for more information on the proper mounting procedures.

Do not attempt to operate this fixture until you have familiarized yourself with its functions.

Do not permit operation by persons not qualified for operating this type of theatrical fixture; most damages are the result of operation by person unfamiliar with the operation of this type of fixture.

If service is ever required, please use the original packaging to transport the fixture in for service.

Power Spot 700 II™

Transportation and Handling

The **POWER SPOT 700 II™** comes with two carrying handles built into the base. Always transport the fixture by these handles. Never lift or carry the **POWER SPOT 700 II™** by the yoke (head assembly) this can seriously damage the unit and will void your manufactures warranty.

Connections

Power supply:

Electronic ballast with:

90~260 Volts, 50~60 Hz,

Grounded contact type plug – Neutrik Powercon

Connected load 1000W \Leftrightarrow 4.5 A (blind current compensation).

NOTE: The universal power supply will accept any voltage source as detailed above without any type of internal or user modifications.

DMX:

USITT DMX 512 Standard input/output, 3 pole connectors.

[+] = Pin 3 / [-] = Pin 2 / [Ground] = Pin 1

Fuse Requirements:

The POWER SPOT 700 II's electronic and lamp systems are protected by two GMA (5x20mm) external fuses:

Lamp: 250v/10A (120v Operation) or 250v/5A (220v Operation)

Electronics: 250v/2A (120v Operation) or 250v/1A (220v Operation)

The fuse requirements are clearly printed on the side of the fixture.

- Always disconnect main power before changing the fuse!
- Always replace with the exact same type fuse unless otherwise specified by an authorized Elation® service technician. Replacing with anything other than the specified fuse can severely damage your fixture and will void your manufactures warranty.

5. FIXTURE LAYOUT

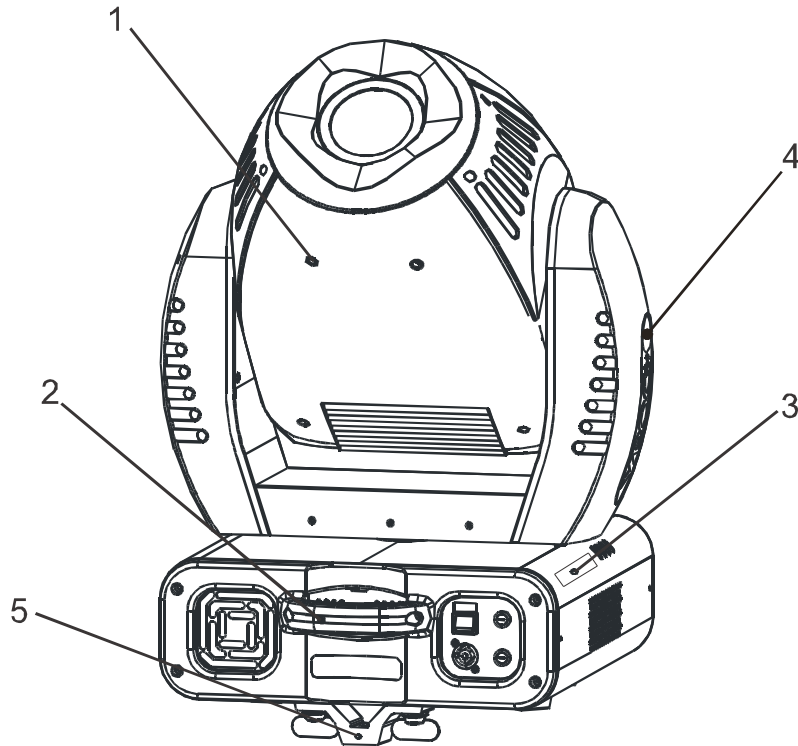

- 1. Moving Head
- 2. Carrying Handles
- 3. LED Menu Display
- 4. Head Tilt Lock
- 5. Omega Clamp

- 6. Ethernet Jack
- 7. 5-Pin DMX Out Connector
- 8. 5-Pin DMX In connector
- 9. Microphone Sensitivity
- 10. Build-In Microphone
- 11. Software-Update Connector
- 12. 3-Pin DMX Out Connector
- 13. 3-Pin DMX In Connector
- 14. Carrying Handle
- 15. Power On/Off
- 16. Lamp Fuse
- 17. Fan (air inlet/outlet)
- 18. Main Power Supply (Powercon)
- 19. Electronics Fuse

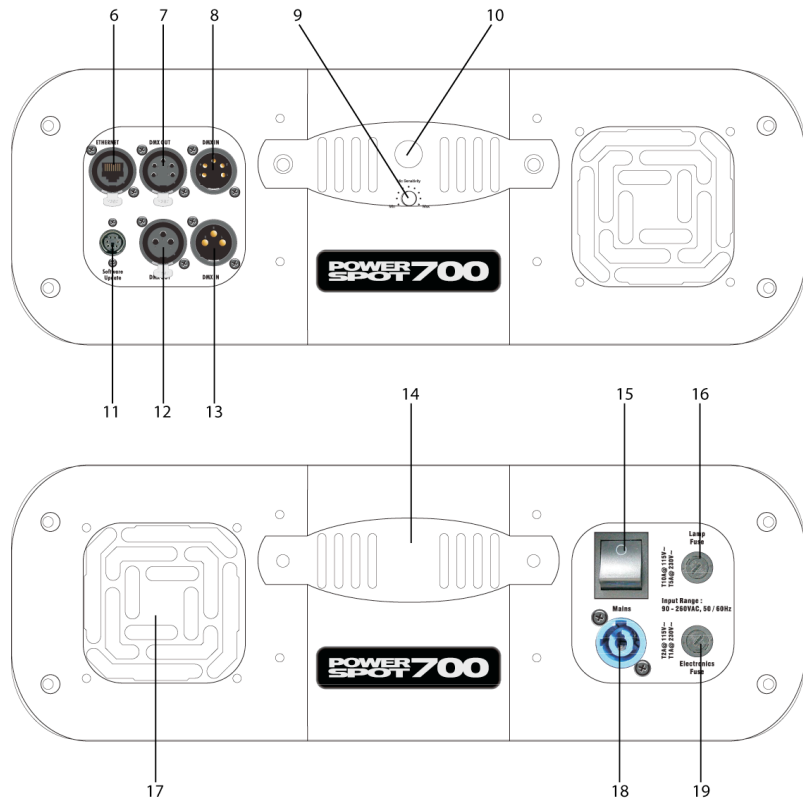

Side View - Menu and Display

20.4-Segment LED Menu

Display

21. Mode Button

22. Enter Button

23. Up Button

24. Down Button

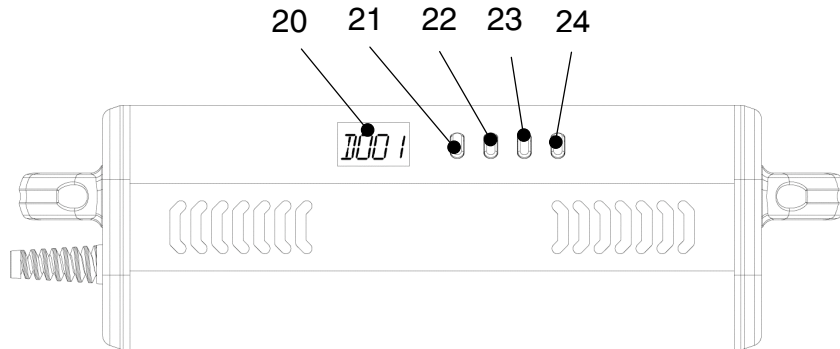

1. **Head Assembly** – The head assembly consist of the main output lens, and either the standard or CMY control module.
2. **Carrying Handle** – The fixtures includes two built-in carrying handles. Be sure to always handle the fixture by the built-in carrying handles. Never lift or carry the fixture by the head or retaining arms as this could cause serious damage to the fixture and void your manufactures warranty.
3. **4-Segment Menu Display** – This display details all the various menu functions. See page 23 for a detailed breakdown of the operating menu.
4. **Tilt Lock** – This lock will hold the head assembly in place for transportation and/or service. Depress the lock button to lock and unlock the head assembly. The head will lock in a 90° or 45° orientation. Always be sure to unlock the head assembly before applying main power to the unit. Failure to do so will result in a start-up error and may damage the unit.
5. **Omega Clamp** - This fixture uses a cam-lock clamp system that allows a quick and efficient means to secure a clamp to the unit. To attach a clamp to the unit, attach a clamp that is rated to handle the weight of the unit to your omega clamp. After a clamp has been attached to the omega clamp, attach the cam locks to the designated position on the bottom of your unit. Lock the cam locks into position by turning the wing nuts 90°. See page 17 for proper clamp mounting and assembly.
6. **Ethernet Jack** – This jack is used for arcnet DMX protocol.

7. **5-PIN DMX Output Jack (CMY Version Only)** – This 5-Pin XLR jack is used to send an outgoing DMX signal. For best results this jack should be terminated if it is the last fixture in a DMX daisy-chain (see termination on page 20).
8. **5-Pin DMX Input Jack (CMY Version Only)** - This 5-Pin XLR jack is used to receive an incoming DMX signal.
9. **Microphone Sensitivity Adjustment Knob** – This knob is used to adjust the frequency sensitivity of the internal microphone when operating in “audio” mode. When the knob is turned counter-clockwise the unit is less sensitive to sound. When the knob is turned clockwise the unit is more sensitive sound.
10. **Built-In Microphone** – The built-in microphone is used to pick-up sound impulse that are used to chase the built-in programs in Sound-Active control.
11. **Firmware Connection** – This connector is for use by an authorized technician only. This connector is used to upgrade the operating software and to test the fixture.
12. **3-PIN DMX Output Jack** – This 3-Pin XLR jack is used to send an outgoing DMX signal. For best results this jack should be terminated if it is the last fixture in a DMX daisy-chain (see termination on page 14).
13. **3-PIN DMX Input Jack** – This 3-Pin XLR jack is used to receive an incoming DMX signal.
14. **Carrying Handle** – The fixtures includes two built-in carrying handles. Be sure to always handle the fixture by the built-in carrying handles. Never lift or carry the fixture by the head or retaining arms as this could cause serious damage to the fixture and void your manufactures warranty.
15. **Power Switch** – The switch is used to control main power to fixture’s electronics.
16. **Lamp Fuse Holder** – This housing holds a 250v/10A GMA fuse (120v operation). Never defeat this fuse. This fuse is designed to protect the lamp in the event of severer power fluctuations. In the event of fuse failure, always be sure to replace this fuse with an exact match unless otherwise instructed by an authorized Elation technician.

17. **Internal Cooling Fan** – This fixture is equipped with two high-velocity variable speed fans mounted in the base to aid in the cooling process. These fans are designed to vary their velocity at different operating temperatures. When the fixture reaches a predetermined internal operating temperature the fans function at high speeds. The higher speeds provide better cooling associated with higher operating temperatures during long use. When the fixture is operating at a lower temperature the fans operate at low speed. Be sure to keep all vents clean, blocked cooling vents can shorten lamp life and reduce the fixtures reliability. For more information on the fan functions see page 30, section 8.10.7.
18. **Powercon Connector** – This power jack is only designed to be used with the Neutrik Powercon adapter included with your fixture. This jack provides main power to your fixture.
19. **Electronics Fuse Holder** – This housing holds a 250v/2A GMA fuse (120v operation). Never defeat this fuse, this fuse is designed to protect the electronics in the event of severer power fluctuations. In the event of fuse failure, always be sure to replace this fuse with an exact match unless otherwise instructed by an authorized Elation technician.
20. **4-Segment Menu Display** – This display details menu functions.
21. **Mode Select Button** – This button is used to access the fixture’s main system menu and on-board programming functions.
22. **Enter Select Button** – This button is used to select and confirm a menu function when working in the fixture’s operating system.
23. **Down Select Button** – This button is used to scroll backwards when navigating through the system menu.
24. **Up Select Button** - This button is used to scroll forward when navigating through the system menu.

6. MOUNTING AND INSTALLATION

Cautions:

For added protection mount the fixtures in areas outside walking paths, seating areas, or in areas where unauthorized personnel might reach the fixture.

Before mounting the fixture to any surface, make sure that the installation area can hold a minimum point load of 10 times the device's weight.

Fixture installation must always be secured with a secondary safety attachment, such as an appropriate safety cable.

Mounting

The POWER SPOT 700 II™ is fully operational in two different mounting positions, hanging upside or set on a flat level surface. To avoid internal damage to the unit, **never mount the unit on its side** as illustrated below. Be sure this fixture is kept at least 1.5 feet away from any flammable materials (decoration etc.). Install a safety cable that can hold at least 10 times the weight of the fixture. Never use the carrying handles for secondary attachment.

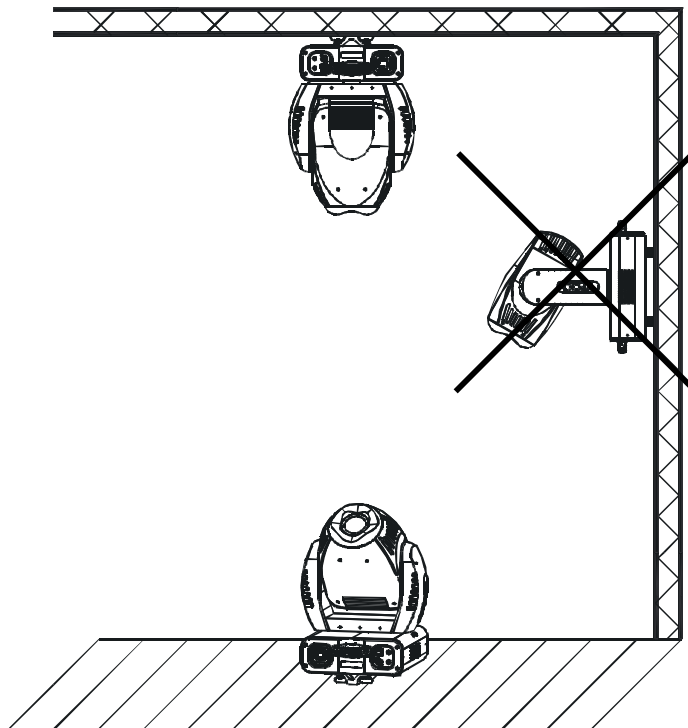



Refer to regulations BGV C1 (formerly VBG 70) and DIN VDE 0711-217 for proper installation in Europe
To ensure proper installation, only qualified staff should attempt installation.

Mounting points

Overhead mounting requires extensive experience, including amongst others calculating working load limits, a fine knowledge of the installation material being used, and periodic safety inspection of all installation material and the fixture. If you lack these qualifications, do not attempt the installation yourself. Improper installation can result in bodily injury.



CAUTION!
Be sure a qualified electrician performs all electrical connections.

Be sure to complete all rigging and installation procedures before connecting the power cord to the appropriate wall outlet.

Clamps

The **POWER SPOT 700 II™** has been designed to hold multiple clamps to the bottom of the unit in several different orientations. Always use an appropriately rated clamp to mount this unit to truss. Refer to the printed instructions on the bottom of the fixture for proper clamp installation.

- a) **Cam lock System:** This system allows a quick and efficient means to secure a clamp to the unit. To attach a clamp to the unit, attach a clamp that is rated to handle the weight of the unit to your cam lock. After a clamp has been attached to the cam lock, attach the cam locks to the designated position on the bottom of your unit. Lock the cam locks into position by turning the wing nuts 90°.

Power Spot 700 II™

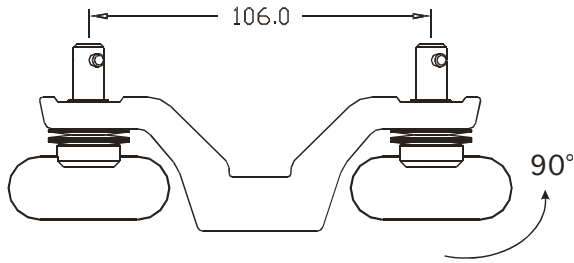

- b) Be sure to always use two cam locks mounted to the bottom of unit to ensure safe truss mounting (each two opposite threads max. M10x20).

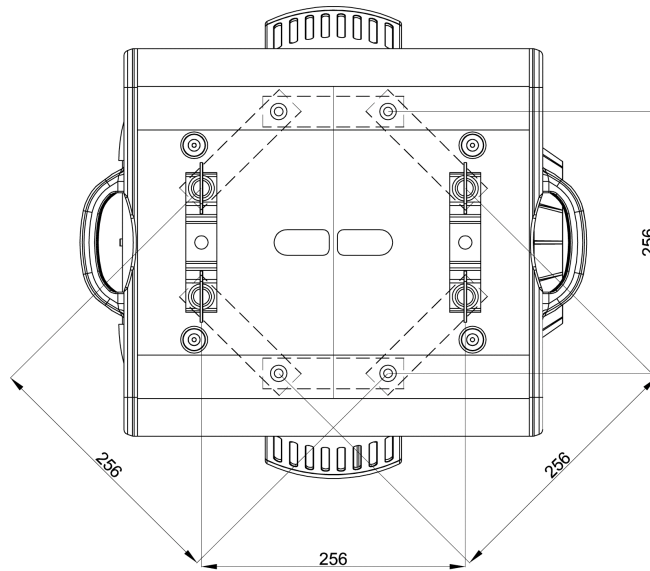

Cam-Lock fasteners position scheme

Secure the POWER SPOT 700 II™

Regardless of the rigging option you choose for your **POWER SPOT 700 II™** always be sure to secure your fixture with a safety cable. The fixture provides a built-in rigging point for a safety cable on the underside of the fixture, be sure to use this point and never secure a safety cable to a carrying handle.

7. UNDERSTANDING DMX

DMX-512: DMX is short for Digital Multiplex. This is a universal protocol used by most lighting and controller manufactures as a form of communication between intelligent fixtures and controllers. DMX allows all makes and models of different manufactures to be linked together and operate from a single controller. This is possible as long as all the fixtures and the controller are DMX compliant. A DMX controller sends the DMX data instructions to the fixture allowing the user to control the different aspects of an intelligent light. DMX data is sent out as serial data that travels from fixture to fixture via data “IN” and data “OUT” XLR terminals located on the fixtures (most controllers will only have output jacks).

DMX Linking: To ensure proper DMX data transmission always use proper DMX cables (not microphone cables) and a terminator. When using several DMX fixtures try to use the shortest cable path possible. Never split a DMX line with a “Y” style connector. The order in which the fixtures are connected in a DMX line does not influence the DMX addressing. For example; a fixture assigned a DMX address of 1 may be placed anywhere in the DMX chain, at the beginning, at the end, or anywhere in the middle. The DMX controller knows to send data assigned to address 1 to that fixture no matter where it is located in the DMX chain. The DMX address is set electronically using the controls on the LCD menu.

Data Cable (DMX Cable) Requirements (For DMX and Master/Slave Operation): Your fixture and your DMX controller require a standard 3-pin or 5-pin XLR connector for data input and data output (the figure on the next page is of a 3-Pin XLR connector). If you are making your own cables, be sure to use two conductor shielded DMX cable rated at 120 ohms; this cable is designed for DMX transmission and may be purchased from your Elation dealer or at most professional lighting retailers. Keep in mind that although microphone cable may look similar to DMX cable it does not share the same resistance rating and may be susceptible to line interference. Please always use proper DMX cables for your data transmission. Your cables should be made with a male and female XLR connector on either end of the cable. Also, remember that a DMX line must be daisy

Power Spot 700 II™

chained and cannot be split, unless using an approved DMX splitter such as the Elation Opto Branch 4™ or DMX Branch/4™.

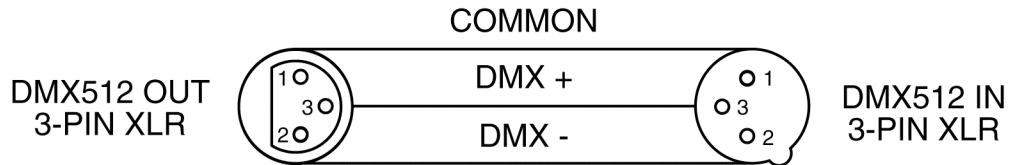

Be sure to follow the above figure when making your own cables. Do not use the ground lug on the XLR connector. Do not connect the cable's shield conductor to the ground lug or allow the shield conductor to come in contact with the XLR's outer casing. Grounding the shield could cause a short circuit and erratic behavior.

DMX Output
3-Pin XLR Socket



DMX Input
3-Pin XLR Socket

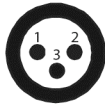

- 1: Ground
- 2: Data (-)
- 3: Data (+)

DMX Output
5-Pin XLR Socket



DMX Input
5-Pin XLR Socket

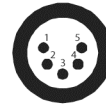

- 1: Ground
- 2: Data (-)
- 3: Data (+)
- 4: Open
- 5: Open

DMX-512 control connection

Connect the provided XLR cable to the female 3-pin XLR output of your controller and the other side to the male 3-pin XLR input of the moving head (Please refer to the diagram below.). You can chain multiple moving heads together through serial linking. The cable needed should be two conductor, shielded cable with XLR input and output connectors. Always be sure daisy chain your in and out data connections, never split or “Y” your DMX connections unless you are using an approved DMX splitter such as the Elation Opto Branch 4™ or DMX Branch/4™.

DMX-512 connection with DMX terminator

A DMX terminator should be used in all DMX lines especially in longer runs. The use of a terminator may avoid erratic behavior in your DMX line. A terminator is a 120 ohm 1/4 watt resistor that is connected between pins 2 and 3 of a male XLR connector (DATA + and

Power Spot 700 II™

DATA -). This fixture is inserted in the female XLR connector of the last fixture in your daisy chain to terminate the line. Using a *line terminator (Elation part: DMX T PACK)* will decrease the possibilities of erratic behavior.

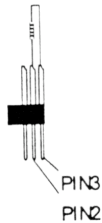
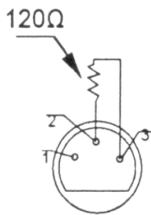

Termination reduces signal errors and avoids signal transmission problems and interference. It is always advisable to connect a DMX terminal, (Resistance 120 Ohm 1/4 W) between PIN 2 (DMX-) and PIN 3 (DMX +) of the last fixture.

5-Pin XLR DMX Connectors. Some manufactures use 5-pin XLR connectors for DATA transmission in place of 3-pin. 5-pin XLR fixtures may be implemented in a 3-pin XLR DMX line. When inserting standard 5-pin XLR connectors in to a 3-pin line a cable adaptor must be used, these adaptors are readily available at most electric stores. The following chart details a proper cable conversion.

3-Pin XLR to 5-Pin XLR Conversion		
Conductor	3-Pin XLR Female (Out)	5-Pin XLR Male (In)
Ground/Shield	Pin 1	Pin 1
Data Compliment (- signal)	Pin 2	Pin 2
Data True (+ signal)	Pin 3	Pin 3
Not Used		Pin 4 - Do Not Use
Not Used		Pin 5 - Do Not Use

Fixture DMX addressing;

All fixtures should be given a DMX starting address when using a DMX controller, so the correct fixture responds to the correct control signal. This digital starting address is the channel number from which the fixture starts to “listen” to the digital control information sent out from the DMX controller. The allocation of this starting DMX address is achieved by setting the correct DMX address on the digital display located on the head of the fixture. You can set the same starting address for all fixtures or a group of fixtures, or set different address for each individual fixture. Be advised that setting all you fixtures to the same

Power Spot 700 II™

DMX address will subsequently control all fixtures in the same fashion, in other words, changing the settings of one channel will affect all the fixtures simultaneously.

If you set each fixture to a different DMX address, each unit will start to “listen” to the channel number you have set, based on the quantity of control channels (DMX channels) of each fixture. That means changing the settings of one channel will only affect the selected fixture.

In the case of the Power Spot 700 II™, which is a 21 channel fixture, you should set the starting DMX address of the first unit to 1, the second unit to 22 (21 + 1), the third unit to 43 (21 + 22), and so on.

Note: During start-up the Power Spot 700 II™, will automatically detect whether a DMX data signal is being received or not. If DMX data signal is being received, the display will show "**D.XXX**" (XXX representing the actual DMX address). If the fixture is not receiving a DMX signal the display will flash "**D.XXX**" (XXX representing the actual DMX address).

If your fixture is connected to a DMX controller and the display is flashing (not receiving a DMX signal), please check the following:

- **The 3-PIN or 5-PIN XLR input plug (cable with DMX signal from controller) is not connected or is not inserted completely into the DMX input jack of the fixture.**
- **The DMX controller is switched off or defective.**
- **The DMX cable or connector is defective.**
- **A DMX terminator has been inserted into the last fixture in your DMX chain.**

8. FIXTURE MENU

The control panel located on the side of the fixture allows you to access the main menu and make all necessary adjustments to the **POWER SPOT 700™**. During normal operation, tapping the “**MODE**” key once will access the fixture’s main menu. Once in the main menu you can navigate through the different functions and access the sub-menus with the **Up** and **Down** buttons. Once you reach a field that requires adjusting, tap the **ENTER** button to activate that field and use the **UP** and **Down** button to adjust the field. Tapping the **Enter** button once more will confirm your setting. Once a setting is saved the LED will briefly readout **OK** to confirm a new setting has been made and locked into memory. You may exit the main menu at any time without making any adjustments by tapping the **MODE** button.

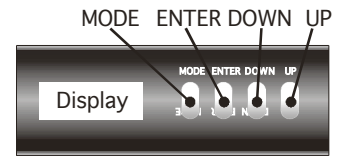

			Remark	
	LEVEL 1	LEVEL 2	LEVEL 3	
	DMX1			Define the DMX start address
	TEST			Test program of all functions
	AUD1	ASLW		Self-running audio program (slow)
		AFST		Self-running audio program (fast)
		MSTR		Master for the audio program
		SVPT		Basic position for the audio program
		SIZE		Size for the audio program (NORM-BIG-MIDL-SMAL)
	LAMP			Switch on/of the lamp direct at the Power Spot 700
	RESE			Reset
	TIME	POWR		Running time of the fixture (no destructible)
		LA1		Running time of the lamp (erasable)
		LA2		Running time of the lamp (no destructible)
	RPAN			Reverse Pan-direction
	RTL			Reverse Tilt-direction
	DMOD	NORM		DMX Mode: Defines the number of DMX channels
		EXT		DMX Mode NORM has to be selected at the moment.
	SPEC	MANU		Manual drive of all device functions
		LARU		Automatic lamp start
		DLDF		Switch off lamp via DMX
		DMX1		Reed out actual DMX-values
		DISP	DM ON	Display On/Off
			REV	Twist the display (also pushing Up/Down keys at the same time)
		LHER		Function not yet in use
		LBAS		Function not yet in use
		TEMP		Internal Temperature Reading

Power Spot 700 II™

<i>FANS</i>	<i>HIGH</i>	Reed out internal temperature
	<i>REG</i>	Maximum cooling fan velocity
	<i>LOOF</i>	Automatic cooling fan control
	<i>LOHI</i>	Low cooling fan speed → lamp off
<i>ADJU</i>	<i>CODE</i>	Use the code for entering the calibration menu (for authorized persons only)
	<i>XXXX</i>	
	<i>COL 1</i>	Calibration of the color wheel 1
	<i>COL 2</i>	Calibration of the color wheel 2
	<i>GOB 1</i>	Calibration of the gobo wheel 1
	<i>GOB 2</i>	Calibration of the gobo wheel 2
	<i>GOB 3</i>	Calibration of the gobo wheel 3
	<i>SH T</i>	Calibration Shutter: Top side
	<i>SH B</i>	Calibration Shutter: Bottom side
	<i>PRIS</i>	Calibration of the prism wheel
	<i>IRIS</i>	Calibration of the iris
	<i>POFS</i>	Calibration of the Pan-Offsets
	<i>TOFS</i>	Calibration of the Tilt-Offsets
	<i>CLRE</i>	Settings in the internal memory (super-user only)
	<i>ARES</i>	Adjust Reset (wheels stand still after the reset)
	<i>VTIL</i>	Software version Tilt-board
	<i>VTR 1</i>	Software version driver board 1
	<i>VTR 2</i>	Software version driver board 2
	<i>VTR 3</i>	Software version driver board 3
<i>DEBUG</i>	Function not yet in use	
<i>COAD</i>	<i>CODE</i>	Use the code for entering the calibration menu (for authorized persons only)
	<i>XXXX</i>	
	<i>COL 2</i>	Coarse calibration of the color wheel 2
	<i>COL 1</i>	Coarse calibration of the color wheel 1
<i>DFSE</i>		Call on the default function values
<i>FEED</i>		Pan/Tilt feedback (error correction) On/Off
<i>EFLG</i>		Correction of faults

8.1 Setting/Changing the DMX Address

After applying power to the **POWER SPOT 700™** the LED will display the fixture's current DMX address immediately after the reset sequence. If the fixture is not receiving a DMX signal the display will flash continuously.



To set or adjust a DMX address, please follow the procedure below:

1. Switch on the **POWER SPOT 700™** and wait for the fixture reset process to finished ('**RESE**' will flash in the LED while fixture is in reset mode).

2. Press the **Mode** button to access the main menu. Toggle through the menu by pressing the **Up** and **Down** buttons until the display shows D001. Tap the enter button to make changes to the address, the current three digit address will immediately begin to flash.
3. While the current three-digit address is flashing, use the **Up** and **Down** buttons to select adjust the address. Lock your new address into the unit's memory by pressing the **Enter** button. After the new address has been successfully stored into the fixture's memory the LED will briefly readout **OK**.

The DMX address is non-destructible and will remain in the fixture's memory even when the power has been switched off. Memory is backed-up and retained by an internal power source with a five year shelf life.

8.2 Test Program



The **Test** Program engages the fixture's internal test mode. This function runs a complete test procedure of all functions. Press **Enter** to launch the self-test or the **Mode** button to cancel and return to the main menu.

8.3 Audio Program



The **Audio** menu allows you to run a stand-alone audio program. This program can run either fast (**AFST**) or slow (**Aslw**); Fast (**AFST**): When running in "fast" mode every sound impulse will trigger a new step. (**Aslw**): When running in You may run several fixtures together at once to achieve a synchronized light show running to sound in a Master/Slave configuration.

Additionally you can choose a basic position for this audio chaser. Use either the internal manual mode or an external DMX controller to set the desired Pan/Tilt position. Confirm this setting in the **SVPT** menu by pressing the **Enter button**.

You can also set the size of the audio chaser in the **SIZE** menu. You have the choice between: NORM (no basic position has to be chosen), 'BIG', 'MIDL' and 'SMAL').

If you want to run several units in a Master/Slave system be sure designate your first unit in the chain as the master. All others must be "Slave" Master = OFF. **Notice:** The Audio function is only working if no DMX is connected.

8.4 Lamp On/Off



This function allows you to manually control the lamp operation. Access the lamp function in the main menu and use the **Up** and **Down** buttons to toggle between lamp **On** and lamp **Off**. Press the **Enter** button to confirm the operation or the **Mode** button to cancel and return to the main menu. (The lamp **OFF** command will only functions if and when the shutter is closed at the same time).

8.5 Reset



This function will rest and return all motors to the home position. Access the reset function in the main menu and press the Enter button to engage the reset function (**RST** will readout in the display).

8.6 Running Time (lamp/unit)



This menu function will read out three different fixture running times.

<i>POWR</i>	Fixture running time (non destructible). Total running time logged by the unit.
<i>LA 1</i>	Lamp running time (erasable). Press and hold down the Up and Down buttons together for three seconds to reset this function.
<i>LA 2</i>	Lamp running time (non destructible). Total lamp hours logged by the unit

8.7 Invert Pan Movement



This function allows you to invert all pan movements. Use the **Up** and **Down** buttons to turn this function **On** and **Off**. Press the **Enter** button to accept the change or the

Mode button to cancel and return to the main menu.

8.8 Invert Tilt Movement



This function allows you to invert all tilt movements. Use the **Up** and **Down** buttons to turn this function **On** and **Off**. Press the **Enter** button to accept the change or the **Mode** button to cancel and return to the main menu.

8.9 Special Functions



This menu option accesses several special features and function of the **POWER SPOT 700™**. The **SPEC** sub-menu consists of several sub-menus. Navigation details of the special functions and their sub-menus are as followed:

8.9.1 Manual Drive



This feature allows you to drive all the unit's functions manually for use in an environment that requires a static position (no movements), determining focus points, or testing. Use the **Up** and **Down** buttons to select the function you wish to adjust, then use the **Enter** button to accept your selection. Now adjust the values with the **Up** and **Down** buttons and use the **Enter** button to lock in your value. Use the **Mode** button to cancel at any time.

Function	Value	Remark
<i>PAN</i>	<i>000 - 255</i>	Pan Position
<i>TILT</i>	<i>000 - 255</i>	Tilt Position
<i>COL 1</i>	<i>000 - 255</i>	Color wheel 1
<i>COL 2</i>	<i>000 - 255</i>	Color wheel 2
<i>GOB 1</i>	<i>000 - 255</i>	Gobo wheel 1
<i>GRT 1</i>	<i>000 - 255</i>	Gobo wheel 1 rotation

<i>G0B2</i>	<i>000 - 255</i>	Gobo wheel 2
<i>GRT2</i>	<i>000 - 255</i>	Gobo wheel 2 rotation
<i>G0B3</i>	<i>000 - 255</i>	Gobo wheel 3
<i>SHUT</i>	<i>000 - 255</i>	Shutter/Strobe functions ~ Lamp will strike at a channel value of 255 if the dimmer channel is at a value of 255 (Open)
<i>DIMR</i>	<i>000 - 255</i>	Dimmer
<i>FOCU</i>	<i>000 - 255</i>	Focus
<i>ZOOM</i>	<i>000 - 255</i>	Zoom
<i>FRST</i>	<i>000 - 255</i>	Frost
<i>PRIS</i>	<i>000 - 255</i>	Prism (000 – 127) / Stop / Prism- rotation
<i>IRIS</i>	<i>000 - 255</i>	Iris
<i>SPEC</i>	<i>000 - 255</i>	Lamp Off, Reset, ...
<i>MOVE</i>	<i>000 - 255</i>	Movements
<i>SPEJ</i>	<i>000 - 255</i>	Speed for Pan/Tilt

8.9.2 Lamp On (automatic lamp strike)



This function automatically strikes lamp when main power is turned on. If you would prefer to strike the lamp through a DMX controller you must turn this function off. To toggle between “OFF” and “ON” use the **Up** and **Down** buttons. Use the **Enter** button to confirm your setting.

Please note: **ON** is the default setting for this function.

8.9.3 Lamp Off via DMX



This function allows the lamp to be switched off through a DMX controller. To enable this function use the **Up** and **Down** buttons to toggle between **ON** and **Off**. Turn this function “ON” to allow DMX switching. Use the **Enter** button to accept your selection or the **Mode** button to cancel and return to the menu.

8.9.4 DMX Input



Power Spot 700 II™

This function will display the DMX value of a channel in the LED as the fixture receives it. Use the **Up** and **Down** buttons to select desired channel and press **Enter** to read its value.

Function	Value	Remark
<i>PAN</i>	<i>000 - 255</i>	Pan Position
<i>TILT</i>	<i>000 - 255</i>	Tilt Position
<i>COL 1</i>	<i>000 - 255</i>	Color wheel 1
<i>COL 2</i>	<i>000 - 255</i>	Color wheel 2
<i>GOB 1</i>	<i>000 - 255</i>	Gobo wheel 1
<i>GRT 1</i>	<i>000 - 255</i>	Gobo wheel 1 rotation
<i>GOB 2</i>	<i>000 - 255</i>	Gobo wheel 2
<i>GRT 2</i>	<i>000 - 255</i>	Gobo wheel 1 rotation
<i>GOB 3</i>	<i>000 - 255</i>	Gobo wheel 3
<i>SHUT</i>	<i>000 - 255</i>	Shutter / Strobe function
<i>DIMR</i>	<i>000 - 255</i>	Dimmer
<i>FOCU</i>	<i>000 - 255</i>	Focus
<i>ZOOM</i>	<i>000 - 255</i>	Zoom
<i>FRST</i>	<i>000 - 255</i>	Frost
<i>PRIS</i>	<i>000 - 255</i>	Prism wheel (000 - 127) / Stop / Prism- Rotation
<i>IRIS</i>	<i>000 - 255</i>	Iris
<i>SPEC</i>	<i>000 - 255</i>	Lamp Off, Reset, ...
<i>MOVE</i>	<i>000 - 255</i>	Movement
<i>SPE 1</i>	<i>000 - 255</i>	Speed for Pan/Tilt

8.9.5 Display



Use this function to choose between different display indications. Use the Up/Down-keys to select desired function and press Enter to confirm or Mode to cancel and return to the menu.

<i>DISP</i>	Display On/Off (If you've chosen off, the display will go out within 15 seconds after the last input. The next key touch will reactivate the display).
<i>REV</i>	Rotates the display by a 180° - This may also be accomplished by pressing both the "UP" and "DOWN" buttons at the same time.

8.9.6 Fixture Temperature



This function allows you to read out the actual fixture operating temperature. Press the **Enter** button to select this function or the **Mode** button to cancel and return to the main menu. Normal operating temperature should range between 85°C and 95°C. Operating temperatures between 96°C and 104°C are considered critical. Temperatures above 105°C will send the fixture into protect mode and automatically switch the lamp off, the lamp will remain off until internal temperature drops below 95°C. Outside surface temperature should not exceed 45°C.

8.9.7 Fan Control



By using this function you can choose between 4 types of fan speed operations. Use the **Up** and **Down** buttons to select the desired fan setting, then press **Enter** to accept your setting or press the **Mode** button to cancel and return to the menu. The chart below will detail the different fan settings:

<i>HIGH</i>	The cooling fan works continuously at max. speed.
<i>REG</i>	This is the default fan setting. In this setting an internal thermal sensor constantly monitors the internal operating temperature and regulates the fan speed to coincide with the internal temperature.
<i>LODF</i>	This function is designed for environments that require low ambient noise. In this setting the fan will operate at the lowest speed. When the maximum internal intolerable operating temperature is reached the lamp will automatically shut off.
<i>LOHI</i>	In this setting the fan will operate at the lowest speed. When the maximum internal intolerable operating temperature is reached the fan will automatically switch from low to high speed.

8.9.8 Adjustments and Calibrations



With this function you can adjust and calibrate the positions of the different wheels and other motors. This feature is reserved for a service technician and is sometimes required after a service or repair work.

This function requires a service code only available to authorized service technicians.

Use the **Up** and **Down** buttons to select the function that requires calibration and press the **Enter** button to confirm the adjustment or the **Mode** button to cancel and return to the menu. Use the **Up** and **Down** buttons to set the adjustment values and confirm once more with the **Enter** button or use the **Mode** button to cancel the operation.

Function	Value	Remark
<i>ADJU</i>	<i>CODE XXXX</i>	Adjustments in the internal setup are code protected (for authorized persons only).
<i>COL 1</i>	<i>- 99 - + 99</i>	Adjustment of the Color wheel 1
<i>COL 2</i>	<i>- 99 - + 99</i>	Adjustment of the Color wheel 2
<i>GOB 1</i>	<i>- 99 - + 99</i>	Adjustment of the Gobo wheel 1
<i>GOB 2</i>	<i>- 99 - + 99</i>	Adjustment of the Gobo wheel 2
<i>GOB 3</i>	<i>- 99 - + 99</i>	Adjustment of the Gobo wheel 3
<i>SH T</i>	<i>- 99 - + 99</i>	Adjustment Shutter: Top side
<i>SH B</i>	<i>- 99 - + 99</i>	Adjustment Shutter: Bottom side
<i>PRIS</i>	<i>- 99 - + 99</i>	Adjustment of the Prism wheel
<i>IRIS</i>	<i>- 99 - + 99</i>	Adjustment of the Iris
<i>POFS</i>	<i>- 99 - + 99</i>	Adjustment of the Pan-Offsets
<i>TOFS</i>	<i>- 99 - + 99</i>	Adjustment of the Tilt-Offsets
<i>CLRE</i>	Adjustments in the internal circuit.	
<i>ARES</i>	<i>- 99 - + 99</i>	Adjust Reset (wheels stand still after the reset)
<i>VTIL</i>	<i>- 99 - + 99</i>	Software version of Tilt-board
<i>VTR 1</i>	<i>- 99 - + 99</i>	Software version of Head- board
<i>VTR 2</i>	<i>- 99 - + 99</i>	Software version of Base- board
<i>VTR 3</i>	<i>- 99 - + 99</i>	Software version of board no. 4
<i>DDUG</i>	<i>- 99 - + 99</i>	Function not yet available

8.9.9 Default Settings



This function is used to restore all the factory default settings and presets. Press the **Enter** button to confirm this operation or the **Mode** button to cancel and return to the menu. When this operation is selected the LED will briefly readout **ok**, then return to the previous function. The chart below details the factory defaults.

Function	Display	Default Settings	
DMX Address	0001	0001	
Pan reverse	RPAN	ON	OFF ✓
Tilt reverse	RTL T	ON	OFF ✓
Automatic lamp on	LAAU	ON	OFF ✓
Lamp on via DMX	LOF	ON ✓	OFF
Display	DISP	ON ✓	REV
Cooling fan	FANS	HIGH REG ✓	LOOF LOHI
Feedback	FEE	ON ✓	OFF

8.9.10 Feedback "APC"



The POWER SPOT 700™ is equipped with "APC," automatic position correction. This function automatically corrects the Pan and Tilt movement should the unit lose step or is obstructed and forced to lose step. Press the **Enter** button to access the sub-menu. Use the **Up** and **Down** buttons to toggle between "ON" and "OFF" and confirm once more with the **Enter** button or use the **Mode** button to cancel the operation.

8.9.11 Error and Fault Corrections



(These functions are reserved for authorized technicians only)

8.10 Display Error and Information Messages

<i>HEAT</i>	This message appears if you try to switch on the lamp within 5 minutes after having switched off (lamp too hot). The message will appear on the display if the lamp doesn't ignite within 20 seconds. The fixture will store this command and automatically ignite the lamp after 5 minutes.
<i>IG E</i>	When igniting the lamp, the electronic ballast will examine whether the lamp ignited or not. If the lamp does not ignite within 20 seconds, the igniting sequence is terminated. The fixture will wait approximately 2 minutes and attempt the lamp ignition process once again. After the 3rd unsuccessful ignition attempt the sequence is completely stopped and the display reads " IG E " (Ignition error).
<i>LAER</i>	After the ignition of the lamp was two times not successful the display will show LAER. That means the lamp could be damaged or even missed, the fixture is overheating or there could be a failure on the igniter or ballast. Switch off the power supply and solve the possible problem.
After the error " <i>IG E</i> " respectively " <i>LAER</i> " it is not anymore possible the start the lamp via Shutter = 255. Nevertheless if a renewed ignition attempt is desired, first run a Reset (at the Spot or over DMX). Afterwards you can try again to ignite the lamp.	
<i>OTMP</i>	This error message informs you that the fixture was overheating and lamp has electronically been switched off to allow the fixture to cool to normal operating temperatures. Please look for any possible reason that may have caused the fixture to overheat. i.e., faulty fans, air vents blocked or dirty, lamp broken or very old, too high ambient temperature. Switch off the power supply and solve the possible problem.
<i>RSER</i>	This message informs you that one of the fixture function wasn't able to do its reset correct (magnetic sensor, stepping motor, driver on the PCB, cables, etc.). Repair the defect and start the fixture again.
<i>MS E</i>	The Power Spot 700 has an automatic detector for the optical effects module (software version 1.28 and later). It detects whether the Power Spot 700 is equipped with a standard Spot module (YSDT) or a CMY module (YCMY). In case the module is not correctly mounted or is in need of service, the display will read MS E (Module Error)

9. OPERATION

Operating Modes: The Power Spot 700 II™ can operate in three different modes. This next section will detail the differences in the operating modes.

- **Stand-alone mode** - The fixture will react to sound, chasing through the built-in programs.
- **Master/Slave mode** - **You** can daisy chain up to 16 fixtures together to get a synchronized light show without the need of an external controller. The fixtures will react to sound chasing to synchronized light show.
- **DMX control mode** - **This** function will allow you to control each individual fixtures traits with a standard DMX-512 controller such as the Elation® Show Designer 2.

9.1 Universal DMX Control: This function allows you to use a universal DMX-512 controller such as the Elation® Show Designer 3™ or Elation® Show Designer 2CF™ to control head movement, the color wheel, the shutter (strobe), and all other DMX traits. A DMX controller allows you to create unique programs tailored to your individual needs. The Power Spot 700 II™ uses 21 DMX channels. See page 37 for detailed description of the DMX traits. To control your fixture in DMX mode, follow the set-up procedures beginning on page 19 of this manual as well as the set-up specifications that are included with your DMX controller. Use the controller's faders to control the various DMX fixture traits. This will allow you to create your own programs.

9.1.1 Follow the instruction on page 24 to set the DMX address.

9.1.2 Be sure to use a terminator on the last fixture.

9.1.3 For help operating in DMX mode consult the manual included with your DMX controller.

9.2 Stand-Alone Operation (Sound Active): This mode allows a single fixture to run to the beat of the music. Only use this mode when running a single fixture, or when running several fixtures as individuals.

9.2.1 Mount your fixture in a secure and stable manner.

- 9.2.2 Access the main menu and select the AUDI function, this will give you access to the audio submenu. See page 25 for the menu breakdown.
- 9.2.3 In the audio submenu choose the audio chase speed, fast or slow. Slow (ASLW) will trigger the chase sequence to every two beats, while fast (AFST) will trigger the chase impulse every beat. See page 25 for more details.
- 9.2.4 Be sure the Master (MSTR) function is switched “ON,” and the SVPT function is switched “OFF.”
- 9.2.5 Choose your room size. The size function allows you to choose the approximate size of the room (NORM, BIG, MIDL, SMAL). The built-in programs will automatically adjust to your selection to optimize light output for your room.
- 9.2.6 Use the sound sensitivity knob on the side control panel to make the unit more or less sensitive to sound. Turning the knob in clockwise direction will make the unit more sensitive to sound, while turning the knob counter-clockwise will make the unit less sensitive to sound. Note: This unit will react to the low frequencies of a sound source, tapping on the fixture or high-pitched sound may not trigger the fixture.

9.3 Master-Slave Operation (Sound Active): This function will allow you to link up to 16 fixtures together and operate without a controller. The fixtures will be sound activated. In Master-Slave operation one fixture will act as the controlling fixture and the others will react to the controlling fixtures programs. Any fixture can act as a Master or as a Slave.

9.3.1 Using standard XLR microphone cables, daisy chain your fixtures together via the XLR connector on the rear of the fixtures. Remember the Male XLR connector is the input and the Female XLR connector is the output. The first fixture in the chain (master) will use the female XLR connector only - The last fixture in the chain will use the male XLR connector only. For longer cable runs we suggest a terminator at the last fixture.

9.3.2 Follow the same procedures listed in the previous Stand-Alone section.

Power Spot 700 II™

With two exceptions; be sure the first unit in the chain is selected as the “master” (MSTR) is turned on in the audio submenu. All other fixtures must be in “slave” mode (SVPT) turned on in the audio submenu.

10. DMX CHANNEL TRAITS (DMX PROTOCOL)

Channel	Function	Time and Value	DMX	HEX	%
1) Pan	0..530°	Min. 2.65 s	0..255	00..FF	0..100
2) Pan-fine	High-Pos ... High-Pos + 2.1° (16 Bit)		0..255	00..FF	0..100
3) Tilt	0..285°	Min. 1.8 s	0..255	00..FF	0..100
4) Tilt-fine	High- Pos ... High- Pos + 1.1° (16 Bit)		0..255	00..FF	0..100
5) Color 1 (fast)	Open (fast)	Chaser from color to color max. 140 BPM => 0.43 s	0..1	00..01	0.2
	Open / Color 1 (fast)		2..3	02..03	1.0
	Color 1. Red (fast)		4..5	04..05	1.8
	Color 1 / Color 2 (fast)		6..7	06..07	2.5
	Color 2. Magenta (fast)		8..9	08..09	3.3
	Color 2 / Color 3 (fast)		10..11	0A..0B	4.1
	Color 3. Purple (fast)		12..13	0C..0D	4.9
	Color 3 / Color 4 (fast)		14..15	0E..0F	5.7
	Color 4. Blue (fast)		16..17	10..11	6.5
	Color 4 / Color 5 (fast)		18..19	12..13	7.3
	Color 5. Green (fast)		20..21	14..15	8.0
	Color 5 / Color 6 (fast)		22..23	16..17	8.8
	Color 6. Yellow (fast)		24..25	18..19	9.6
	Color 6 / Color 7 (fast)		26..27	1A..1B	10.4
	Color 7. Orange (fast)		28..29	1C..1D	11.2
	Color 7 / Color 8 (fast)		30..31	1E..1F	12.0
	Color 8. Dark Blue (fast)		32..33	20..21	12.7
	Color 8 / Color 9 (fast)		34..35	22..23	13.5
	Open (fast)		36..63	24..3F	15..25
	Open (slow)	Chaser from color to color max. 70 BPM => 0.86 s	64..65	40..41	25.3
	Open / Color 1 (slow)		66..67	42..43	26.1
	Color 1. Red (slow)		68..69	44..45	26.9
	Color 1 / Color 2 (slow)		70..71	46..47	27.6
	Color 2. Magenta (slow)		72..73	48..49	28.4

Power Spot 700 II™

Channel	Function	Time and Value	DMX	HEX	%
	Color 2 / Color 3 (slow)		74..75	4A..4B	29.2
	Color 3. Purple (slow)		76..77	4C..4D	30.0
	Color 3 / Color 4 (slow)		78..79	4E..4F	30.8
	Color 4. Blue (slow)		80..81	50..51	31.6
	Color 4 / Color 5 (slow)		82..83	52..53	32.4
	Color 5. Green (slow)		84..85	54..55	33.1
	Color 5 / Color 6 (slow)		86..87	56..57	33.9
	Color 6. Yellow (slow)		88..89	58..59	34.7
	Color 6 / Color 7 (slow)		90..91	5A..5B	35.5
	Color 7. Orange (slow)		92..93	5C..5D	36.3
	Color 7 / Color 8 (slow)		94..95	5E..5F	37.1
	Color 8. Dark Blue (slow)		96..97	60..61	37.8
	Color 8 / Color 9 (slow)		98..99	62..63	38.6
	Open (slow)		100..127	64..7F	40..50
	Color Rotation STOP		128..129	80..81	50.1
	Color rotation, slow-fast, CW	Min. 1.4 turns/h	130..191	82..BF	51..75
	Color rotation, fast-slow, CCW	Max. 2.9 turns/sec.	192..253	C0..FD	76..98
	Audio color chaser slow	Each 4 th sound impulse → new color	254	FE	99
	Audio color chaser fast	Each sound impulse → new color	255	FF	100
6) Color 2 (fast)	Open (fast)	Chaser from color to color max. 140 BPM => 0.43 s	0..1	00..01	0.2
	Open / Color 1 (fast)		2..3	02..03	1.0
	Color 1. Green (fast)		4..5	04..05	1.8
	Color 1 / Color 2 (fast)		6..7	06..07	2.5
	Color 2. Brilliant Blue (fast)		8..9	08..09	3.3
	Color 2 / Color 3 (fast)		10..11	0A..0B	4.1
	Color 3. Pink (fast)		12..13	0C..0D	4.9
	Color 3 / Color 4 (fast)		14..15	0E..0F	5.7
	Color 4. Red (fast)		16..17	10..11	6.5

Power Spot 700 II™

Channel	Function	Time and Value	DMX	HEX	%
	Color 4 / Color 5 (fast)		18..19	12..13	7.3
	Color 5. Yellow (fast)		20..21	14..15	8.0
	Color 5 / Color 6 (fast)		22..23	16..17	8.8
	Color 6. Light Green (fast)		24..25	18..19	9.6
	Color 6 / Color 7 (fast)		26..27	1A..1B	10.4
	Color 7. CTO (fast)		28..29	1C..1D	11.2
	Color 7 / Color 8 (fast)		30..31	1E..1F	12.0
	Color 8. CTC (fast)		32..33	20..21	12.7
	Color 8 / Color 9 (fast)		34..35	22..23	13.5
	Open (fast)		36..63	24..3F	15..25
	Open (slow)	Chaser from color to color max. 70 BPM => 0.86 s	64..65	40..41	25.3
	Open / Color 1 (slow)		66..67	42..43	26.1
	Color 1. Brilliant Blue (slow)		68..69	44..45	26.9
	Color 1 / Color 2 (slow)		70..71	46..47	27.6
	Color 2. Green (slow)		72..73	48..49	28.4
	Color 2 / Color 3 (slow)		74..75	4A..4B	29.2
	Color 3. Pink (slow)		76..77	4C..4D	30.0
	Color 3 / Color 4 (slow)		78..79	4E..4F	30.8
	Color 4. Red (slow)		80..81	50..51	31.6
	Color 4 / Color 5 (slow)		82..83	52..53	32.4
	Color 5. Yellow (slow)		84..85	54..55	33.1
	Color 5 / Color 6 (slow)		86..87	56..57	33.9
	Color 6. Light Green (slow)		88..89	58..59	34.7
	Color 6 / Color 7 (slow)		90..91	5A..5B	35.5
	Color 7. CTO Filter (slow)		92..93	5C..5D	36.3
	Color 7 / Color 8 (slow)		94..95	5E..5F	37.1
	Color 8. CTC Filter (slow)		96..97	60..61	37.8
	Color 8 / Color 9 (slow)		98..99	62..63	38.6
	Open (slow)		100..127	64..7F	40..50

Power Spot 700 II™

Channel	Function	Time and Value	DMX	HEX	%
	Color Rotation STOP		128..129	80..81	50.1
	Color rotation, slow-fast, CW	Min. 1.4 turns/h	130..191	82..BF	51..75
	Color rotation, fast-slow, CCW	Max. 2.9 turns/sec.	192..253	C0..FD	76..98
	Audio color chaser slow	Each 4 th sound impulse → new color	254	FE	99
	Audio color chaser fast	Each sound impulse → new color	255	FF	100
7) Gobo 1 (indexed)	Gobo 1 (open. fast)	Chaser from gobo to gobo max. 100 BPM => 0.6 s	0..7	0..7	0..2.9
	Gobo 2 (fast)		8..15	8..F	3..5.9
	Gobo 3 (fast)		16..23	10..17	6..8.9
	Gobo 4 (fast)		24..31	18..1F	9..11.9
	Gobo 5 (fast)		32..39	20..27	12..14.9
	Gobo 6 (fast)		40..47	28..2F	15..17.9
	Gobo 7 (fast)		48..55	30..37	18..20.9
	Gobo 8 (fast)		56..63	38..3F	21..23
	Gobo 1 (open. slow)	Chaser from gobo to gobo max. 40 BPM => 1.51 s	64..71	40..47	24..26.9
	Gobo 2 (slow)		72..79	48..4F	27..29.9
	Gobo 3 (slow)		80..87	50..57	30..33.9
	Gobo 4 (slow)		88..95	58..5F	34..36.9
	Gobo 5 (slow)		96..103	60..67	37..39.9
	Gobo 6 (slow)		104..111	68..6F	40..42.9
	Gobo 7 (slow)		112..119	70..77	43..45.9
	Gobo 8 (slow)		120..127	78..7F	46..49
	Gobo rotation STOP		128..129	80..81	50
	Gobo rotation, slow-fast, CW	Min. 1.4 turns/h	130..191	82..BF	51..75
	Gobo rotation, fast-slow, CCW	Max. 1.0 turns/sec.	192..253	C0..FD	76..98
	Audio gobo chase, slow	Each 4 th sound impulse → new gobo	254	FE	99
	Audio gobo chase, fast	Each sound impulse → new gobo	255	FF	100

Power Spot 700 II™

Channel	Function	Time and Value	DMX	HEX	%	
8) Gobo 1 Posi./Rot	Gobo Position 0 ... 540°		0..127	00..7F	0..49	
	Gobo Rotation STOP		128..129	80..81	50	
	Gobo Rotation. Slow-fast. CW	Min. 2.0 turns/h	130..191	82..BF	51..75	
	Gobo Rotation. Fast-slow. CCW	Max. 3.8 turns/sec.	192..253	C0..FD	76..100	
	Audio Gobo Rotation. Slow	Each 4 th sound impulse → new position	254	FE	99	
	Audio Gobo Rotation. Fast	Each sound impulse → new gobo	255	FF	100	
9) Gobo 2 (indexed)	Gobo 1 (open. fast)	Chaser from gobo to gobo max. 100 BPM => 0.6 s	0..7	0..7	0..2.9	
	Gobo 2 (fast)		8..15	8..F	3..5.9	
	Gobo 3 (fast)		16..23	10..17	6..8.9	
	Gobo 4 (fast)		24..31	18..1F	9..11.9	
	Gobo 5 (fast)		32..39	20..27	12..14.9	
	Gobo 6 (fast)		40..47	28..2F	15..17.9	
	Gobo 7 (fast)		48..55	30..37	18..20.9	
	Gobo 8 (fast)		56..63	38..3F	21..23	
	Gobo 1 (open. slow)	Chaser from gobo to gobo max. 40 BPM => 1.51 s	64..71	40..47	24..26.9	
	Gobo 2 (slow)		72..79	48..4F	27..29.9	
	Gobo 3 (slow)		80..87	50..57	30..33.9	
	Gobo 4 (slow)		88..95	58..5F	34..36.9	
	Gobo 5 (slow)		96..103	60..67	37..39.9	
	Gobo 6 (slow)		104..111	68..6F	40..42.9	
	Gobo 7 (slow)		112..119	70..77	43..45.9	
	Gobo 8 (slow)		120..127	78..7F	46..49	
		Gobo rotation STOP		128..129	80..81	50
		Gobo rotation, slow-fast, CW	Min. 1.4 turns/h	130..191	82..BF	51..75
		Gobo rotation, fast-slow, CCW	Max. 1.0 turns/sec.	192..253	C0..FD	76..98
		Audio gobo chase, slow	Each 4 th sound impulse → new gobo	254	FE	99
		Audio gobo chase, fast	Each sound impulse →	255	FF	100

Power Spot 700 II™

Channel	Function	Time and Value	DMX	HEX	%
		new gobo			
10) Gobo 2	Gobo Position 0 ... 540°		0..127	00..7F	0..49
Posi./Rot	Gobo Rotation STOP		128..129	80..81	50
	Gobo Rotation. Slow-fast. CW	Min. 2.0 turns/h	130..191	82..BF	51..75
	Gobo Rotation. Fast-slow. CCW	Max. 3.8 turns/sec.	192..253	C0..FD	76..100
	Audio Gobo Rotation. Slow	Each 4 th sound impulse → new position	254	FE	99
	Audio Gobo Rotation. Fast	Each sound impulse → new gobo	255	FF	100
11) Gobo 3	Gobo 1 (open. fast)	Chaser from gobo to gobo max. 100 BPM => 0.6 s	0..3	00..03	0..1
(fast)	Gobo 2 (fast)		4..7	04..07	2..3
	Gobo 3 (fast)		8..11	08..0B	3..4
	Gobo 4 (fast)		12..15	0C..0F	5..6
	Gobo 5 (fast)		16..19	10..13	6..7
	Gobo 6 (fast)		20..23	14..17	8..9
	Gobo 7 (fast)		24..27	18..1B	9..10
	Gobo 8 (fast)		28..31	1C..1F	11..12
	Gobo 9 (fast)		32..35	20..23	13..14
	Gobo 10 (fast)		36..39	24..27	14..15
	Gobo 1 (open. slow)	Chaser from gobo to gobo max. 40 BPM => 1.51 s	64..67	41..43	25..26
	Gobo 2 (slow)		68..71	44..47	27..28
	Gobo 3 (slow)		72..75	48..4B	28..29
	Gobo 4 (slow)		76..79	4C..50	30..31
	Gobo 5 (slow)		80..83	51..53	32..33
	Gobo 6 (slow)		84..87	54..57	33..34
	Gobo 7 (slow)		88..91	58..5B	35..36
	Gobo 8 (slow)		92..95	5C..5F	36..37
	Gobo 9 (slow)		96..99	60..63	38..39
	Gobo 10 (slow)		100..103	64..67	39..40
	Gobo rotation STOP		128..129	80..81	50

Power Spot 700 II™

Channel	Function	Time and Value	DMX	HEX	%
	Gobo rotation, slow-fast, CW	Min. 1.4 turns/h	130..191	82..BF	51..75
	Gobo rotation, fast-slow, CCW	Max. 1.0 turns/sec.	192..253	C0..FD	76..98
	Audio gobo chase, slow	Each 4 th sound impulse → new gobo	254	FE	99
	Audio gobo chase, fast	Each sound impulse → new gobo	255	FF	100
12) Shutter	Shutter closed		0..15	00..0F	0..6
	Random Strobe (different pattern)		16..31	10..1F	7..11.9
	Strobe Pulse effect, slow - fast	Min. frequency 0.7 Hz	32..47	20..2F	12..12.9
	Audio Shutter		48..63	30..3F	13..25
	Strobe effect, slow - fast	Max. frequency 10 Hz	64..239	40..EF	26..93
	Shutter open (lamp start)		240..255	F0..FF	94..100
13) Dimmer	Dimmer closed (0%)		0..3	0..3	0..1
	Dimmer 1%...99%	Movement time 0.3 sec.	4..251	4..FB	2..98
	Dimmer open (100%)		252..255	FC..FF	99..100
14) Focus	In (near) - out (far)	Full distance 1.5 sec.	0..255	0..FF	0..100
15) Zoom	Inside (near) - outside (far)	Full distance 1.5 sec.	0..255	0..FF	0..100
16) Frost	Open (0%) - retracted (100%)	Full distance 1.5 sec.	0..255	0..FF	0..100
17) Prism	Prism swing out		0..5	00..05	0..2
	Prism position 0 ... 540°		6..129	06..7F	0..50
	Prism rotation stop		130..191	80..BF	51..75
	Prism rotation, slow-fast, CW	Min. 1.6 turns/h	192..253	C0..FD	76..100
	Prism rotation, fast-slow, CCW	Max. 4.4 turns/sec.	254	FE	99
	Audio prism rotation, slow	Each 4 th sound impulse → new prism	255	FF	100
18) Iris	Iris open – closed		0..127	00..7F	00..49
	Ascend with Shutter, random		128..143	80..8F	50..56
	Descend with Shutter, random		144..159	90..9F	56..62
	Ascend with Shutter, audio		160..175	A0..AF	63..68
	Descend with Shutter, audio		176..191	B0..BF	69..74

Power Spot 700 II™

Channel	Function	Time and Value	DMX	HEX	%	
	Ascend with Shutter	Slow - fast	192..207	C0..CF	75..81	
	Descend with Shutter	Slow - fast	208..223	D0..DF	82..87	
	Pulse - effect	Slow - fast	224..239	E0..EF	88..93	
	Ascend - descend effect	Slow - fast	240..253	F0..FD	94..99	
	Iris open		254..255	FE..FF	100	
19) Special	No Function		0..15	00..0F	0..6	
	Gobo1-shake +/- 10° slow – fast	3.5 moves / min. up to 60 moves / max.	16..31	10..1F	7..12	
	Gobo1-shake +/- 20° slow – fast	3.5 moves / min. up to 60 moves / max.	32..47	20..2F	13..18	
	Gobo1-shake +/- 30° slow – fast	3.5 moves / min. up to 60 moves / max.	48..63	30..3F	19..24	
	No function		64..111	40..6F	23..43	
	Color1-Chaser C / C+1 slow – fast	0.7 BPS ... 2.3 BPS => 1.43 s ... 0.43 s	112..127	70..7F	44..50	
	Color1-Chaser C / C+2 slow – fast	0.7 BPS ... 2.0 BPS => 1.43 s ... 0.5 s	128..143	80..8F	51..56	
	No function		144..175	90..AF	57..68	
	Audio Pan / Tilt slow	Each 4 th sound impulse → new position	176..191	B0..BF	69..74	
	Audio Pan / Tilt fast	Each sound impulse → new position	192..207	C0..CF	75..81	
	No function		208..223	D0..DF	82..87	
	Fan min. as long as temp. < 90°C		224..229	E0..E5	88..90	
	Lamp OFF (min. 3 sec.) if Shutter closed '000'		230..249	E6..F9	92..97	
	Reset		250..255	FA..FF	98..100	
20) Move- ment	No movement		0	00	0	
	Movement	Size	Phase			
	PAN	1	0°	01..01	01..01	0.5

Power Spot 700 II™

Channel	Function	Time and Value		DMX	HEX	%	
		1	90°	02..03	02..03	1.0	
		1	180°	04..05	04..05	1.7	
		1	270°	06..07	06..07	2.5	
	PAN	2	0°	08..09	08..09	3.3	
		2	90°	10..11	0A..0B	4.1	
		2	180°	12..13	0C..0D	4.9	
		2	270°	14..15	0E..0F	5.7	
	PAN	3	0°	16..17	11..11	6.5	
		3	90°	18..19	12..13	7.3	
		3	180°	20..21	14..15	8.0	
		3	270°	22..23	16..17	8.8	
	PAN	4	0°	24..25	18..19	9.6	
		4	90°	26..27	1A..1B	10.4	
		4	180°	28..29	1C..1D	11.2	
		4	270°	30..31	1E..1F	12	
	TILT	Size / phase see also PAN		32..63	20..3F	13..25	
	PAN / TILT	Size / phase see also PAN		64..95	40..5F	26..37	
	PAN / TILT (inverse)	Size / phase see also PAN		96..127	60..7F	38..50	
	Circle	Size / phase see also PAN		128..159	80..9F	51..62	
	Circle (inverse)	Size / phase see also PAN		160..191	A0..BF	63..75	
	Lying eight	Size / phase see also PAN		192..223	C0..DF	76..87	
	Random movement	Size see also PAN		224..255	E0..FF	88..100	
21) Speed	Pan/Tilt relative movement			0..15	00..0F	0..6	
Pan/Tilt	Pan/Tilt slow – fast (Channels 1,3, and 23)			Pan Min. 530° = 200 s Pan Max. 530° = 2.65 s Tilt Min. 285° = 110 s Tilt Max. 285° = 1.8 s	16..255	10..FF	7..100

Power Spot 700 II™

Lamp ON	Shutter open	Channel 12	240..25 5	F0..F F	94..10 0
Lamp OFF	Lamp OFF (min. 3 sec.) if Shutter closed '000'	Channel 19 and Channel 12	230..24 9 0	6E..9 F 0	92..97 0
Reset		Channel 19	250..25 5	FA..F F	98..10 0

11. LAMP REPLACEMENT

For a proper and safe lamp change, please read this chapter carefully and follow all instructions.

Safety Regulations

- Pull out the main plug!
- Wait min. 20 minutes after the last operation to cool down the fixture.
- Don't touch the bulb of the lamp with bare fingers (this can cause damages).
- Before you put the POWER SPOT 700™ into operation close the casing, otherwise your retina can be hurt!
- Replace the lamp with an approved replacement type. Be sure to follow all the lamp handling procedures included with your new lamp. Never handle the new lamp with your bare hands, the oils from your skin may damage the lamp. Always replace with the lamp with a lamp that meets the original lamp specification, failure to do so may damage the unit and will void your manufactures warranty.

Lamp Change

1. **Be sure the unit's main power is disconnect before attempting any service procedure!**
2. Always allow ample time for the unit to properly cool before attempting any type of service or repair.
3. To allow the best lamp access, use the tilt-lock system to lock the head in 180° horizontal position.

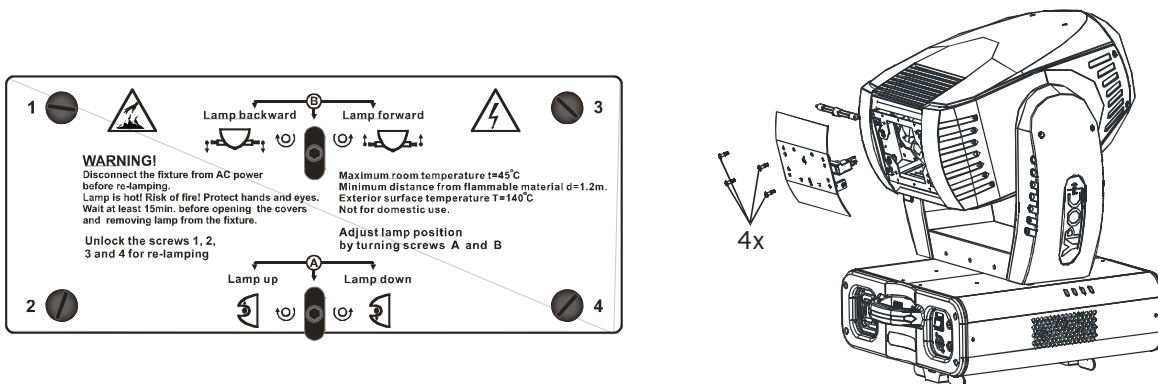

4. Using a standard flat head screwdriver release 1/4 turn quick-lock fasteners (labeled 1, 2, 3, and 4) of the backside lamp sheet and remove it carefully. These

Power Spot 700 II™

fasteners will remain connected to the lamp socket cover.

5. Gently remove the old lamp from it's socket. If the old lamp has exploded be sure to remove all of the old lamp fragments to prevent damage to the internal components.
6. Insert the new lamp securely, locking the lamp in place as illustrated in the diagram to the left. Orientate the lamp filler tube towards the backside of the reflector. Before reassembling the unit, be sure the new lamp is securely seated in the lamp socket. Always be sure to only use specified lamp types!
7. Gently replace the lamp socket assembly in to place and secure with the four quick release fasteners.
8. Be sure to reset the lamp running time in the "TIME" menu. The lamp run time is designed to function as lamp replacement reminder (see page 23).
9. Final step would be to properly optimize the lamp. Follow the steps below to properly align the lamp and inside the reflector.

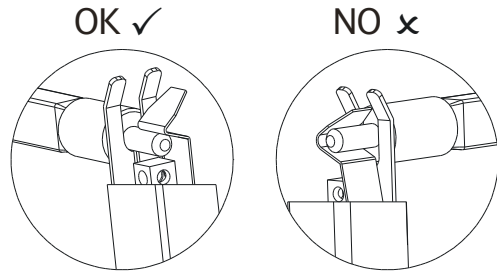

Attention:

Be sure the lamp is securely seated in the lamp socket. Failure to comply with this warning may cause excessive heat build-up that may cause the internal lens to crack.

Lamp Optimization:

You should adjust the lamp position after each lamp replacement. This is necessary due to the fact that every lamp has small manufacturing variations. The Power Spot 700 includes a lamp optimization system, consisting of two set screws on the back lamp socket cover (set screw A and B). The lamp adjustment is a matter of the users taste but will best be done as follows:

1. Using a flathead screwdriver move the lamp position with setscrew "B" forwards and backwards until a very bright luminous spot (hotspot) can be seen clearly.

2. Move lamp with setscrew “A” upward/downwards until this hotspot is in the center of the beam projection.
3. Use setscrew “B” once again to move the lamp forwards and backwards until you've reached the most even beam projection. Note: A slight hotspot will always remain and is conditional to the optical path.

12. FUSE REPLACEMENT

Caution: Always replace with the exact same type fuse, unless otherwise specified by an authorized Elation® service technician. Replacing with anything other than the specified part can damage your unit and will void your manufactures warranty.

Warning: If you continue to blow fuses, STOP using the fixture. Contact customer support for further instructions, you may have to return the unit for servicing. Continuing to use the unit may cause serious damage.

Fuse Replacement: Locate and remove the unit's power cord from the main power supply. Once the cord has been removed located the fuse holders located on the side panel near the power input connection. Using a flat-head screwdriver unlock the fuse holder from its' housing by turning the holder in a counter-clockwise direction. Once the fuse holder has been unlocked, pull back on the fuse holder holder to expose the fuse. Gently pull out the bad fuse and discard of it properly and replace it with an exact match. Reassemble in reverse order.

13. OPTICAL EFFECTS MODULE

The Power Spot 700 II is equipped with an optical effects module that can be easily removed for cleaning, service, and gobo/color exchange. Please follow the procedures below for proper removal and service of the effects module.

13.1 Safety considerations

- *Always remove main power before attempting any type of service procedure.*
- If the fixture has been recently in operation, please allow 15 minutes for the internal components to cool before attempting service.
- During service never touch the lamp with bare fingers as this can damage the lamp and reduce lamp life.
- To prevent personal injury from UV radiation, always be sure the cover is replaced before operating the fixture.

13.2 Removing the optical effects module:

- 1) Please lock the head in a vertical position for easier access.
- 2) Remove the upper shell of the head casing by loosening the four quick-release retaining fasteners. Two on the front side and two on the backside of the head. Hang out the head safely.

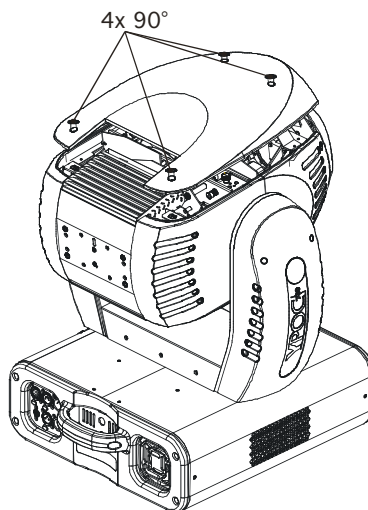

- 3) Disconnect the main "Data Bus" cable from the optical effects module. This is the only connection between the effects module and the fixture's head control board. No other bus cables need to be removed. See illustration below;

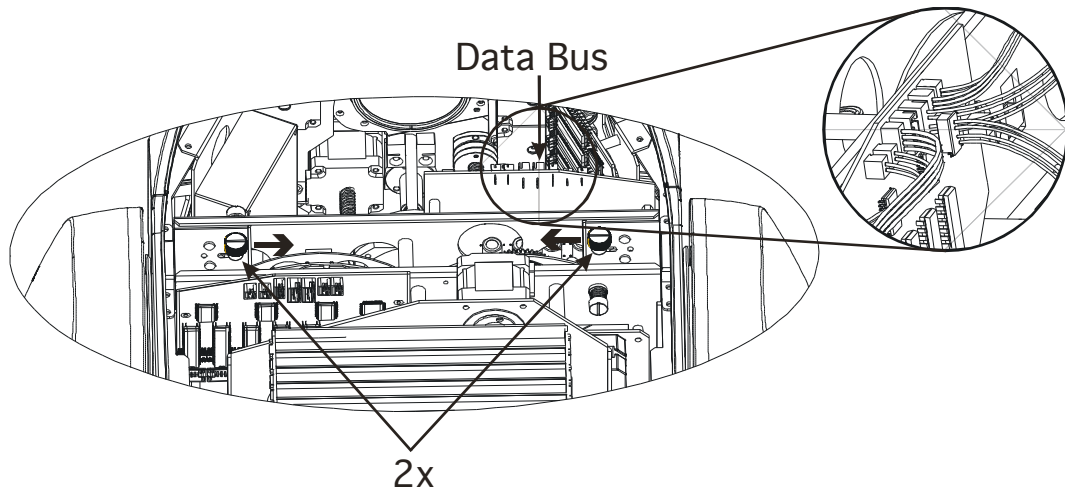

- 4) Loosen the two locking thumbscrews on the left and right side of the optical effects module (please do not attempt to remove the thumbscrews completely). Once the thumbscrews have been loosened push them inwards towards the center of the head while gently pulling the effects module straight out. You may use the metal support plates to grasp and pull the effects module out. See the illustration below;

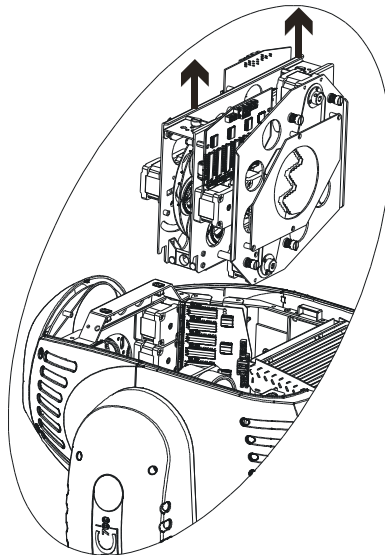

Attention: The effects module reset between two lateral tracks. A moderate effort is normal when attempting to remove the unit. Never use any of the sensitive wheel components like the gobo and color wheels or any cables to remove the module. Use the metal support plates or the stepper motors as a

means to grasp the module.

- 5) To access the internal components of the module loosen the three securing thumbscrews illustrated below. Once these screws are loose you may place the module on a flat and open the unit up as if it were a book. This will allow access to all the gobos and colors so they may be changed or cleaned.

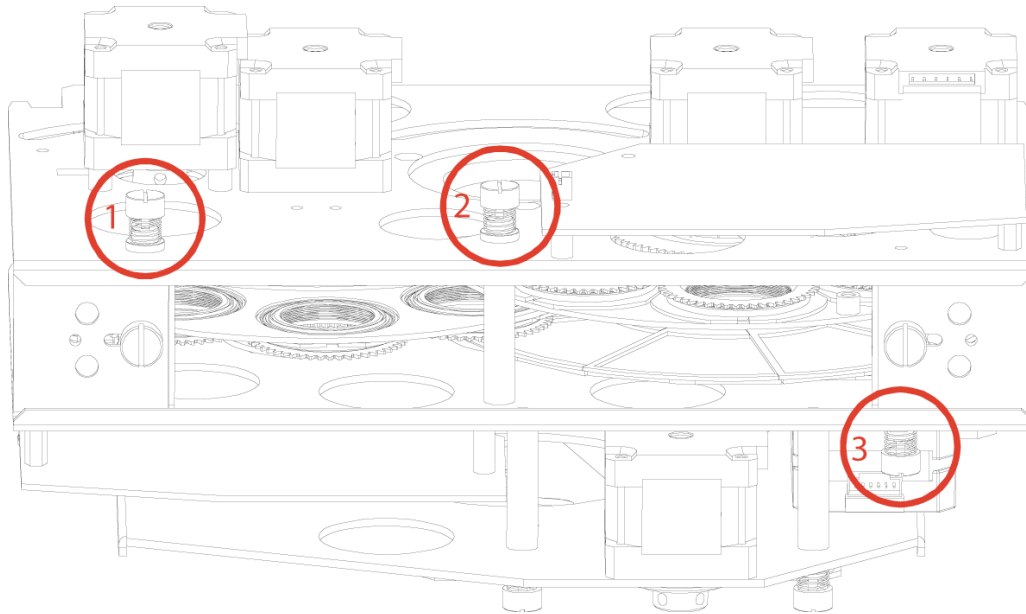

- 6) For Gobo and Color replacement please see the next section.
- 7) To replace module;
 - a) Fold up the module and fasten the three retaining thumbscrews.

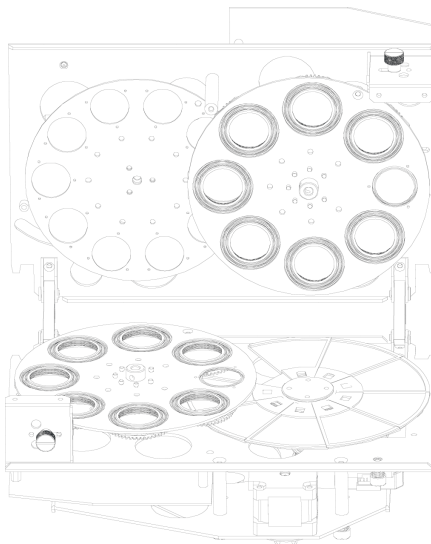

- b) Insert the effects module back in to the fixture and the two lateral tracks. Push it carefully down until the two locking thumbscrews snap in place and hand tighten the retaining thumbscrews.
- c) Connect the "Data Bus" cable into the proper corresponding socket.
- d) Seal the cover in reverse order.

14. CHANGING/REPLACING GOBOS/COLORS

Before attempting to change any gobos or color be sure to follow the effects module removal process as described in the previous section (section 13) of this manual.

The POWER SPOT 700 II includes both Aluminum (thickness = 0.3 mm) and Glass (thickness = 1.1 - 3.0 mm) gobos (outside diameter 26.9 mm, viewable image size 23 mm). There is one rotating Gobos wheel (user replaceable gobos) and one fixed Gobo wheel (non replaceable gobos).

14.1 General guidelines for exchanging Gobos and Colors

All Gobos and Color filters have a specific optical orientation that must be observed. To prevent damage to the gobos and color filters and to optimize the optical image, all effect should be mounted with their reflecting side in the direction of the lamp. For example;

Aluminum Gobos must be mounted with their unpainted side toward the lamp. The black painted side should go in the direction of the front lens.

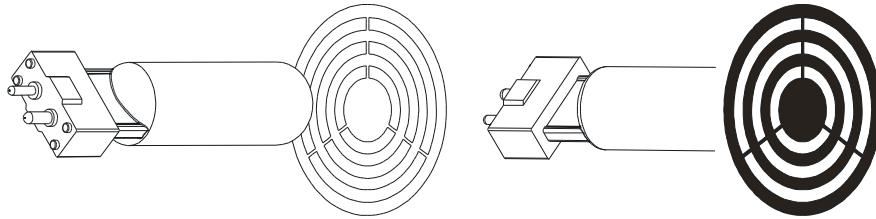

Glass Gobos must be mounted with their reflective side toward the lamp. In the case of glass gobos the reflective side of the gobo is sometimes hard to distinguish. An easy way to distinguish the reflective side is to hold a pencil directly in front of the Gobo. If the pencil is in front of the uncoated side of the gobo you will see thickness of the Glass Gobo between the mirror image and the pencil. This is the reflective side that should be mounted towards the lamp. See the illustration on the next page; notice the pencil image on the left has a mirror reflection further away from the pencil as the mirror reflection on the right.

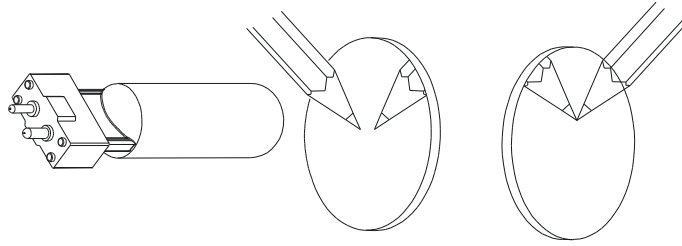

Attention: Custom gobos that contain company logos and text must also be orientated properly to ensure proper display of the custom image. The readable side must be mounted towards the lamp. In the illustration below, notice that the text is readable in the example on the left and mirrored in the example on right. The illustration below details proper gobo placement. Be sure that all custom gobos are ordered so that their reflective side is on the readable side of the image as detailed in the example on the left.

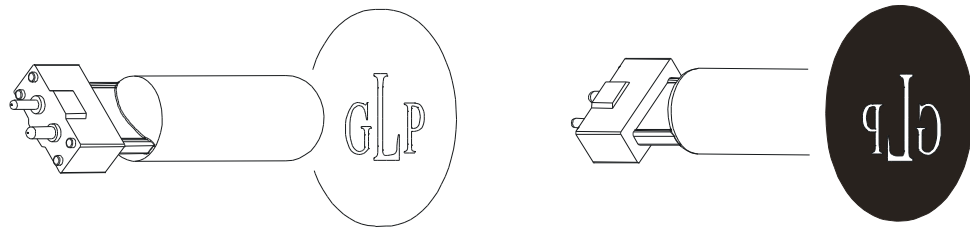

Textured Glass Gobos must be mounted with the textured surface towards the lamp and the flat side towards the front lens.

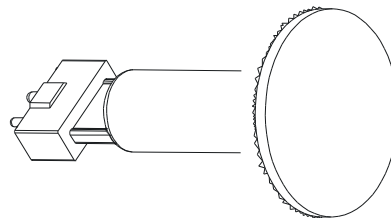

Colored Dichroic Filters are already pre-mounted on the color filter holder that guarantees the correct orientation.

14.2 Changing Gobos

- 1) Be sure the effects module is removed and opened as detailed in the previous section of this manual.
- 2) Gently lift and pull the gobo holder out of the center part of the wheel hub to remove the individual holder. See the left image below.
- 3) Once the gobo holder has been removed the Gobo itself can be replaced by remove the centric spring with a small screwdriver or gripping pliers. Be sure to follow the gobo alignment instructions that are detailed on the previous page of this manual (section 14.1).
- 4) Once the gobo has been exchanged replace the retaining centric spring to hold the gobo in position.
- 5) Place the Gobo holder assembly back into the gobo wheel central hub. A slight snap will ensure that the gobo holder has been correctly and fully inserted back into the gobo wheel hub.

Notice: There must be no gap between the gobo holder assembly and the actual gobo wheel. Be sure to check for a complete and secure fit.

14.3 Changing Color filters

- 1) Be sure the effects module is removed and opened as detailed in the previous section of this manual (section 13.1).
- 2) Pull the Color filter holder carefully out of the central locking spring-holder. Be sure to grasp the color filter by the metal frame and by the glass filter itself.
- 3) Replace the colored filters as needed by inserting the replacements back into the color wheel's central retaining spring. If necessary you may use a small flathead screwdriver to carefully lift the center retaining spring on the color wheel up.

Notice: Please be sure the color filter holder is snapped in completely. Failure to do so may result in damage to the color filter.

Power Spot 700 II™

Power Spot 700 II Gobo Wheels

Special Notice:

If you use glass gobos, the non-vaporized side must be fitted towards the lamp direction.

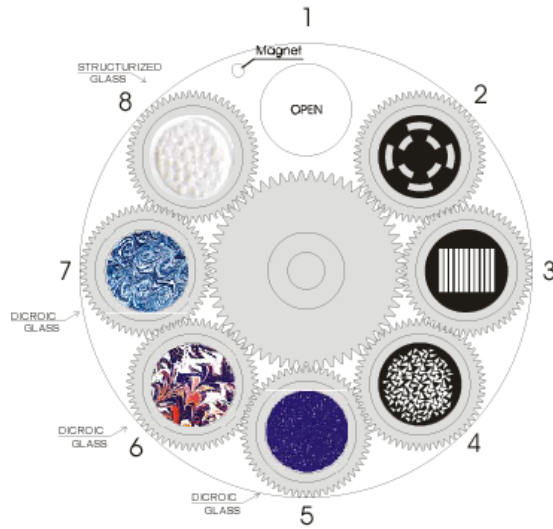

Gobo wheel 1 with rotating Gobos

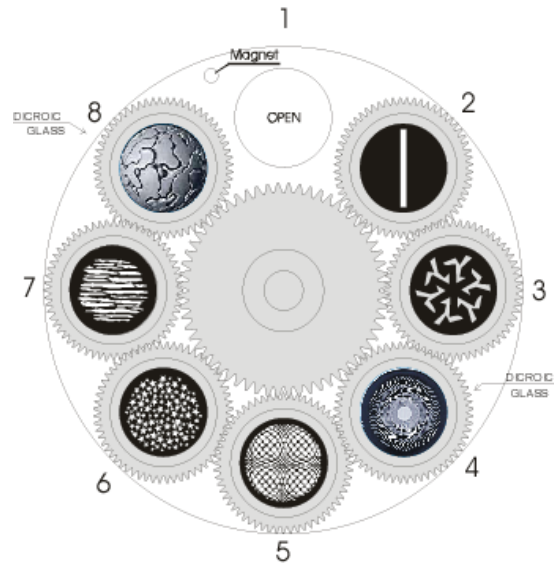

Gobo wheel 2 with rotating Gobos

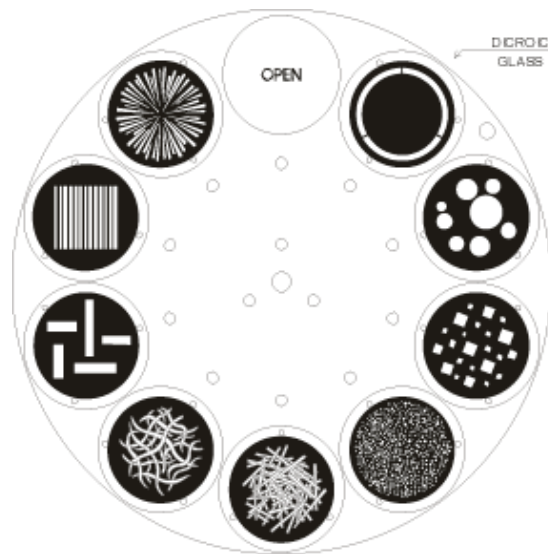

Fixed Gobo wheel

15. MAINTENANCE AND CLEANING

It is absolutely essential that the fixture is kept clean and dust, dirt and smoke-fluid residues do not built-up on the surface or within the fixture. Residue build-up may cause the fixture's light output to be significantly reduced. Regular cleaning will not only ensure the maximum light output, but will also allow the fixture to function reliable throughout its life.

A soft lint-free cloth moistened with any quality glass cleaner is recommended, under no circumstances should alcohol or solvents be used! Stay away from glass cleaner that contains ammonia such as Windex.

The inside optical system should be maintained only by qualified technicians. Please contact Elation professionals for recommendation associated with internal cleaning procedures.

Safety Considerations:

- ***Always disconnect main power before attempting any service related issues!***
- ***Allow ample time for the lamp to cool (at least 20 minutes) before performing any cleaning procedures.***
- ***Never attempt operation with any of the protective covers removed!***

Cleaning Frequency (rule-of-thumb)

The residue build up will very depending on location, therefore only general guidelines are given. Below is a suggested cleaning interval only. Cleaning frequency depends on the environment in which the fixture operates (I.E. smoke, fog residue, dust, dew). In clubs that observe heavier use, we recommend cleaning on a more frequent basis. Periodic cleaning will ensure fixture longevity and crisp lamp output.

Position	Interval	In this way
Outside optic	Weekly	Soft cloth and glass cleaner
Color filter	Monthly	Soft cloth and glass cleaner
Gobos	Yearly	Vacuum cleaner, airbrush, etc.
Glass gobos	Monthly	Soft cloth and glass cleaner
Prism	Monthly	Soft cloth and glass cleaner
Dimmer/Shutter	Yearly	Vacuum cleaner, airbrush, etc.

Power Spot 700 II™

Inside lens	Monthly	Soft cloth <u>no</u> glass cleaner
Fan and air channel	Monthly	Vacuum cleaner, airbrush, etc.
Reflector	Never	
Lamp	Never	
Moveable parts	Yearly	Suitable Lubricant

Caution:

1. **Never** allow the optical parts to come in contact with oil, dirt, or grime.
2. **Allow** all parts to dry completely before attempt operation.
3. **Never** clean the aspheric lens with water or other cleaners. The lens should be changed at the first sign of ware, usually in about 1 – 2 years (lens will begin to look cloudy). For lens replacement please contact Elation technical support.

16. TWO YEAR (730 DAYS) LIMITED WARRANTY

A. Elation Professionals® hereby warrants, to the original purchaser, Elation Professionals® products to be free of manufacturing defects in material and workmanship for a period of two years (730 days) from the date of purchase. This warranty shall be valid only if the product is purchased within the United States of America, including possessions and territories. It is the owner's responsibility to establish the date and place of purchase by acceptable evidence, at the time service is sought.

B. For warranty service, send the product only to the Elation Professionals® factory. All shipping charges must be pre-paid. If the requested repairs or service (including parts replacement) are within the terms of this warranty, Elation Professionals® will pay return shipping charges only to a designated point within the United States. If the entire instrument is sent, it must be shipped in its original package. No accessories should be shipped with the product. If any accessories are shipped with the product, Elation Professionals® shall have no liability whatsoever for loss of or damage to any such accessories, or for the safe return thereof.

C. This warranty is void if the serial number has been altered or removed; if the product is modified in any manner which Elation Professionals® concludes, after inspection, affects the reliability of the product; if the product has been repaired or serviced by anyone other than the Elation Professionals® factory unless prior written authorization was issued to purchaser by Elation Professionals®; if the product is damaged because not properly maintained as set forth in the instruction manual.

D. This is not a service contract, and this warranty does not include maintenance, cleaning or periodic check-up. During the period specified above, Elation Professionals® will replace defective parts at its expense, and will absorb all expenses for warranty service and repair labor by reason of defects in material or workmanship. The sole responsibility of Elation Professionals® under this warranty shall be limited to the repair of the product, or replacement thereof, including parts, at the sole discretion of Elation Professionals®. All products covered by this warranty were manufactured after January 1, 1990, and bare identifying marks to that effect.

E. Elation Professionals® reserves the right to make changes in design and/or improvements upon its products without any obligation to include these changes in any products theretofore manufactured.

Power Spot 700 II™

F. No warranty, whether expressed or implied, is given or made with respect to any accessory supplied with products described above. Except to the extent prohibited by applicable law, all implied warranties made by Elation Professionals® in connection with this product, including warranties of merchantability or fitness, are limited in duration to the warranty period set forth above. And no warranties, whether expressed or implied, including warranties of merchantability or fitness, shall apply to this product after said period has expired. The consumer's and or Dealer's sole remedy shall be such repair or replacement as is expressly provided above; and under no circumstances shall Elation Professionals® be liable for any loss or damage, direct or consequential, arising out of the use of, or inability to use, this product.

G. This warranty is the only written warranty applicable to Elation Professionals® products and supersedes all prior warranties and written descriptions of warranty terms and conditions heretofore published.

H. Lamps are not covered under this or any other warranty either written or implied.

17. PHOTOMETRIC DATA

**Power Spot 700
Photometric Data**

Illuminance (lux or fc): 602500 cd/distance \leq (m or ft)
Beam diameter: ~ 0.24 x distance
Field angle: ~ 13.4°
Color temperature: 7500 Kelvin (no color filters applied)
Measurement conditions: 230V ~ / 50Hz
Measurement source: Osram HTI 700W/D4/75

All information is subject to change without prior notice

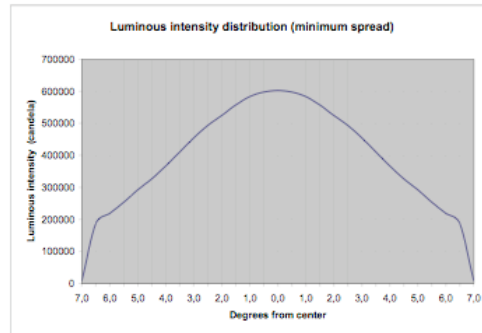
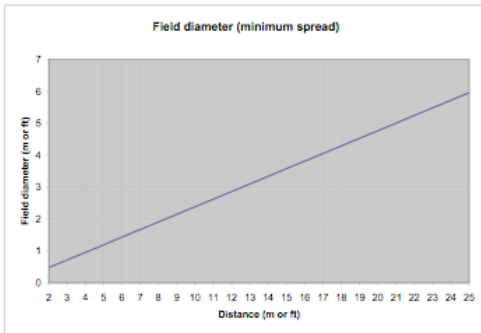
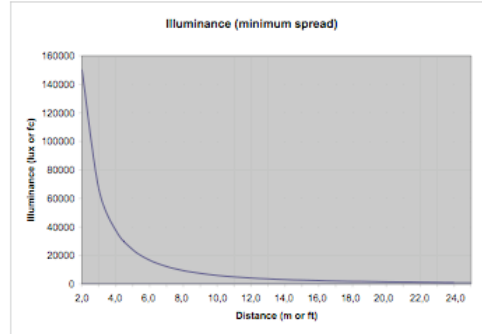

**Power Spot 700
Photometric Data**

Illuminance (lux or fc): 122250 cd/distance \leq (m or ft)
Beam diameter: ~ 0.62 x distance
Field angle: ~ 34.6°
Color temperature: 7500 Kelvin (no color filters applied)
Measurement conditions: 230V ~ / 50Hz
Measurement source: Osram HTI 700W/D4/75

All information is subject to change without prior notice

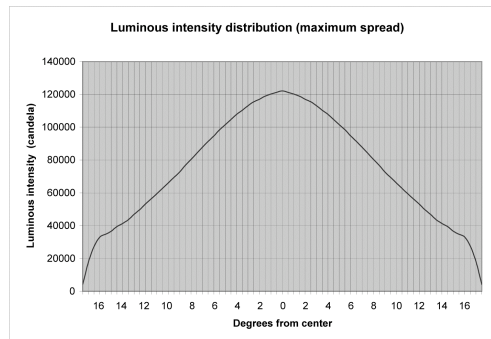
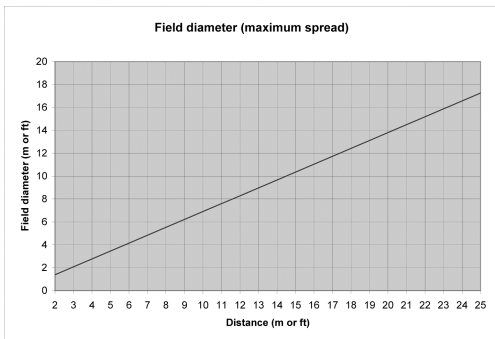
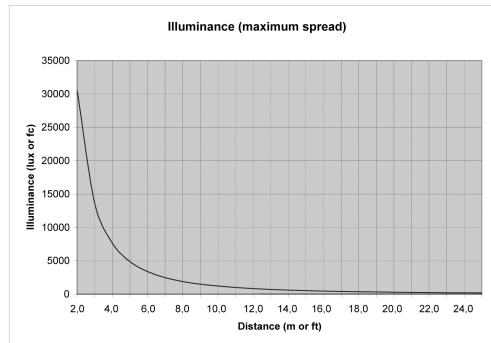

18. DIMENSIONS

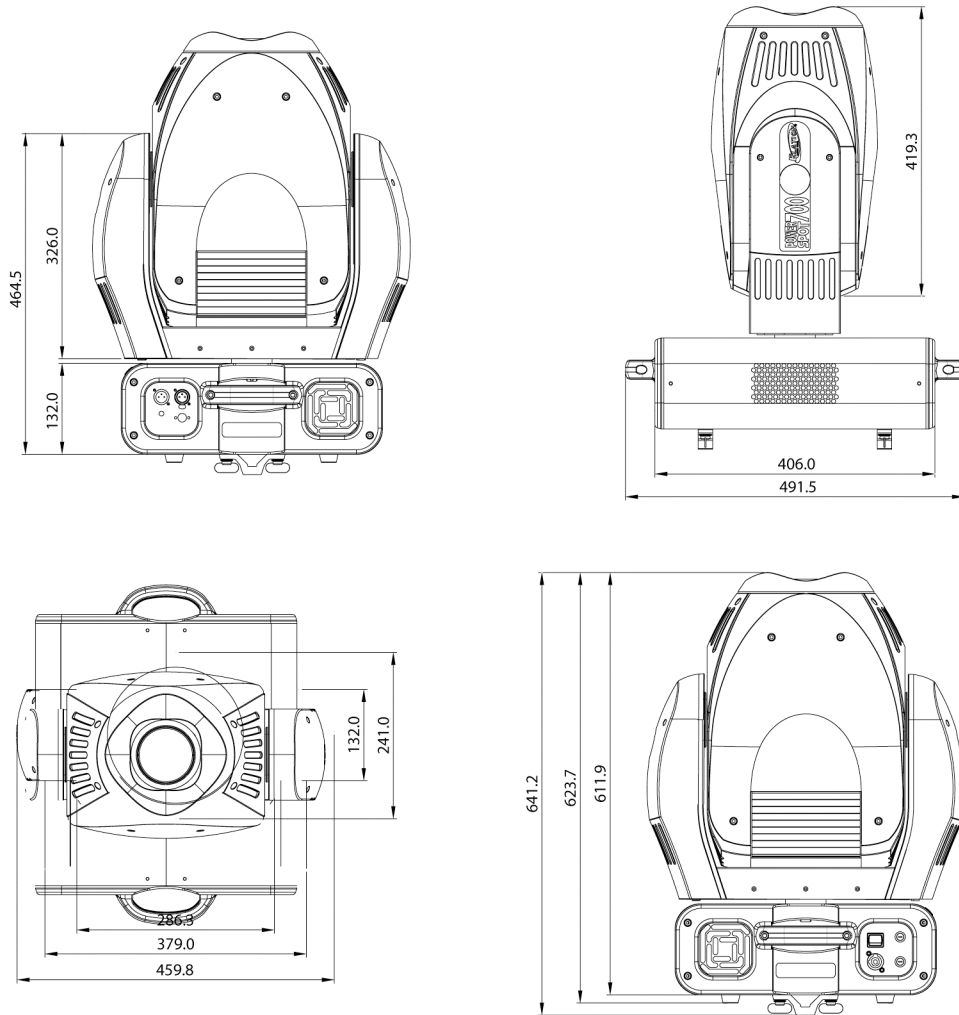

19. TECHNICAL SPECIFICATION

Power supply	
Power consumption	90 ~ 260V, 50 ~ 60 Hz 1000 Watt, 4.5 A, electronic ballast, (blind current compensated)
Fuse protection	Lamp 120v: GMA 10A, 250V, 5x20 mm (fine-wire fuse) Electronic 120v: GMA 2A, 250V, 5x20 mm (fine-wire fuse) Lamp 220v: GMA 5A, 250V, 5x20 mm (fine-wire fuse) Electronic 220v: GMA 1A, 250V, 5x20 mm (fine-wire fuse)
Lamp	
Type	MSR700 SA/DE (Philips Gold)
Live time	750hrs
Color temperature	7500kK
Luminous flux	56,000lm
Optical system	
Dichroic coated glass reflector	
Beam angel (variable) 14° - 32°	
Lenses hardened and tempered, anti-reflex coated	
Colors (16 Bit)	
Color wheel 1: 8 dichroic filters plus white, 9 half colors	
Color wheel 2: 8 dichroic filters plus white, 9 half colors, 1x CTC 5500, 1x CTC 3200	
Gobos (16 Bit)	
Gobo-wheel 1: 7 exchangeable rotating gobos plus "open"	
Gobo-wheel 2: 7 exchangeable rotating gobos plus "open"	
Gobo-wheel 3: 9 fixed exchangeable standard gobos plus "open"	
11 spare Gobos included,	
Gobo outside diameter 26.9 mm, image size 23 mm	
Gobo thickness glass = 1.1 - 3.0 mm / aluminum = 0.3mm	
Gobo wheel 2: 9 fixed aluminum Gobos plus "open" (fixed)	
Shutter / Strobe / Dimmer (16 Bit)	
Strobe- effect with variable speed 1 - 10 flashes per second	
Continuously mechanical dimmer 0 - 100%	
Prism (16 Bit)	
Rotating 3-face prism, rotating and variable in speed	
Focus (16 Bit)	
Motor driven focus from near (2m) to far away	
Iris (16 Bit)	
High-Speed Iris 100% - 4% (0,2 Sec. opening time)	
Zoom (16 Bit)	
Zoom range 14° - 32°	
Drive	

Power Spot 700 II™

Standard DMX-512, 3 pole XLR; [+] = Pin 3 [-] = Pin 2 [Ground] = Pin 1.
The DMX- addressing starts at the DMX- address [001].

Pan / Tilt

Pan - movement	530° in max. 2.65 seconds, 16 bit resolution
----------------	--

Tilt - movement	280° in max. 1.68 seconds, 16 bit resolution
-----------------	--

Weights and measures

Width of the base	490 mm (19.3")
-------------------	----------------

Length of the base	380 mm (15")
--------------------	--------------

Height (head vertical)	646 mm (25.5")
------------------------	----------------

Weight (net)	28.5 kg (63lbs)
--------------	-----------------

Please Note: Specifications and improvements in the design of this unit and this manual are subject to change without any prior written notice.

1. INDEX

A	
Adjustments	23
aspheric lens	40
B	
BGV C1	11
Blind current compensation	13
C	
Calibrations	23
Change a Gobo	37
Connected load	13
D	
Decoration	11
Description of Device	8
DIN VDE 0711-217	11
DMX	13
<i>DMX- Address</i>	18
DMX Protocol	29
E	
Error Messages	25
F	
Feedback	25
Fixture Temperature	23
Fuse	15
G	
Glass Gobos	38

I	
Injury of the retina	7
M	
Maintenance	39
Measures	41
Mounting	11
P	
Pan- movement	41
Power supply	13
R	
Reset	19
Running time	19
S	
Safety Instructions	7
Secure the Power Spot 7000	12
<i>Special Functions</i>	20
T	
Technical Specification	41
<i>Test Program</i>	18
Tilt- movement	41
V	
VBG 70	11
W	
Weights	41

Elation Professional
6122 S. Eastern Ave.
Los Angeles, Ca. 90040
www.ElationLighting.com / info@ElationLighting.com